



SERIE DN-S

DISTANCE SENSORS 30MM E 100MM



MODELLO	NPN	DN S10R	DN S10R J
	PNP	DN S10R PN	DN S10R PN J
Metodo di rilevamento	a soppressione di sfondo		
Distanza di regolabile	30 ... 100mm		
Distanza di lavoro	25 ... 100mm		
Alimentazione	DC 12 ... 24V \pm 10% ondulaz. 10%		
Autoconsumo	33 mA (max.)		
Uscita	Open collector 100 mA DC 30V Max		
Protezione al corto circuito	Incorporato		
Modo operativo	Light-On / Dark-On selezionabile		
Tempo di risposta	0,5 msec (max)		
Isteresi	10% Max		
Sorgente di luce	LED rosso (700nm)		
Indicatori	Operatività: LED arancione ; Stabilità LED verde		
Cavo	cavo volante 2m	con connettore M8	
Peso	50g	8g	

DIMENSIONI DN-S10R

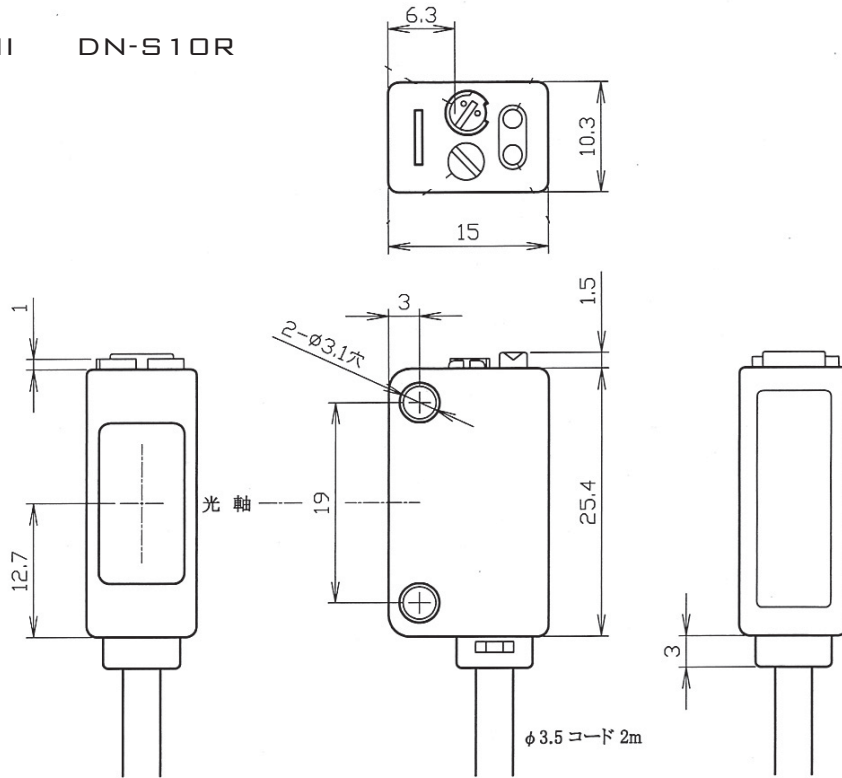

DIMENSIONI DN-S10RJ

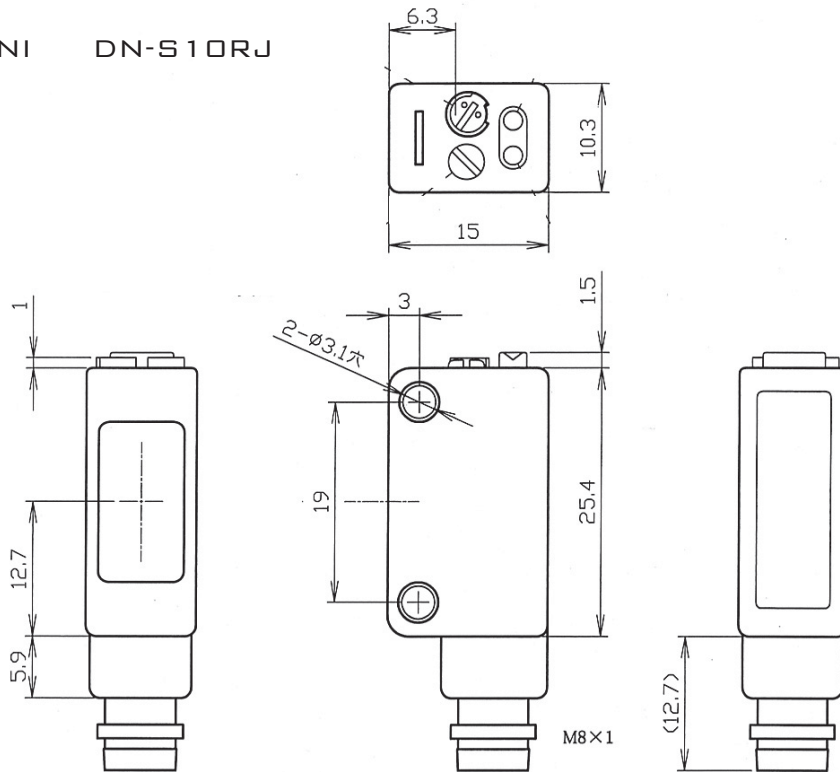

SENSORMATIC SRL

VIA DELLA BEVERARA, 13 - 40131 BOLOGNA (BO)

TEL: 0516353511 - FAX: 051/6346741

WWW.SENSORMATIC.IT - SMBOX@SENSORMATIC.IT