

EP50S Series

Shaft Type Ø50mm Absolute Rotary Encoder

■ Features

- Compact size of external diameter: Ø50mm
- Various output code: BCD, Binary, Gray code
- Various and high resolution (720, 1024-division)
- Protection structure IP64 (dust-proof, oil-proof)

■ Applications

- Precision machine tool, Fabric machinery, Robot, Parking system



⚠ Please read "Caution for your safety" in operation manual before using.



■ Ordering Information

EP50S	8	-	1024	-	1	-	R	-	P	-	24
Series	Shaft diameter	Steps/revolution	Output code	Revolution direction	Control output	Power supply					
Ø50mm shaft type	Ø8mm	Refer to resolution	1: BCD code 2: Binary code 3: Gray code	F: Output value increase at CW direction R: Output value increase at CCW direction	P: PNP open collector output N: NPN open collector output	5 : 5VDC ±5% 24: 12-24VDC ±5%					

■ Specifications

Item		Shaft Type Ø50mm Absolute Rotary Encoder								
Resolution		6, 8, 10, 12, 16, 20, 24, 32, 40, 45, 48, 64, 90, 128, 180, 256, 360, 512, 720, 1024-division								
Output code		BCD code	Binary code	Gray code		BCD code	Binary code	Gray code		
Electrical specification	Output phase / Output angle ^{*1}	1024-division	TS: 0.3515°±15' (13-bit)	TS: 0.3515°±15' (10-bit)	TS: 0.703°±15' (10-bit)	20-division	TP1: 12°±60' (1-bit)	TP1: 12°±60' (1-bit)	TP1: 12°±60' (1-bit)	
		720-division	TS: 0.5°±25' (11-bit)	TS: 0.5°±25' (10-bit)	TS: 1°±25' (10-bit)		TP2: 2°±60' (1-bit)	TP2: 2°±60' (1-bit)	TP2: 2°±60' (1-bit)	
		512-division	TS: 0.703°±15' (11-bit)	TS: 0.703°±15' (9-bit)	TS: 1.406°±15' (9-bit)		TS: 18°±60' (5-bit)	TS: 18°±60' (5-bit)	TS: 18°±60' (5-bit)	
		360-division	TS: 1°±25' (10-bit)	TS: 1°±25' (9-bit)	TS: 2°±25' (9-bit)	16-division	TP1: 15°±60' (1-bit) TP2: 2°±60' (1-bit) TS: 22.5°±60' (5-bit) EP: 22.5°±60' (1-bit)	TP1: 15°±60' (1-bit) TP2: 2°±60' (1-bit) TS: 22.5°±60' (4-bit) EP: 22.5°±60' (1-bit)	TP1: 15°±60' (1-bit) TP2: 2°±60' (1-bit) TS: 45°±60' (4-bit) EP: 22.5°±60' (1-bit)	
		256-division	TS: 1.406°±15' (10-bit)	TS: 1.406°±15' (8-bit)	TS: 2.8125°±15' (8-bit)					
		180-division	TS: 2°±25' (9-bit)	TS: 2°±25' (8-bit)	TS: 4°±25' (8-bit)					
		128-division	TS: 2.8125°±15' (9-bit)	TS: 2.8125°±15' (7-bit)	TS: 5.625°±15' (7-bit)					
		90-division	TS: 4°±25' (8-bit)	TS: 4°±25' (7-bit)	TS: 8°±25' (7-bit)	12-division		TP1: 15°±60' (1-bit) TP2: 3°±60' (1-bit) TS: 30°±60' (4-bit) EP: 30°±60' (1-bit)	TP1: 15°±60' (1-bit) TP2: 3°±60' (1-bit) TS: 60°±60' (4-bit) EP: 30°±60' (1-bit)	
		64-division	TS: 5.625°±15' (7-bit)	TS: 5.625°±15' (6-bit)	TS: 11.25°±15' (6-bit)					
		48-division	TS: 7.5°±25' (7-bit)	TS: 7.5°±25' (6-bit)	TS: 15°±25' (6-bit)					
		45-division	TS: 8°±25' (7-bit)	TS: 8°±25' (6-bit)	TS: 16°±25' (6-bit)	10-division	TP1: 30°±60' (1-bit) TP2: 12°±60' (1-bit) TS: 36°±60' (4-bit) EP: 36°±60' (1-bit)	TP1: 30°±60' (1-bit) TP2: 12°±60' (1-bit) TS: 72°±60' (4-bit) EP: 36°±60' (1-bit)	TP1: 30°±60' (1-bit) TP2: 12°±60' (1-bit) TS: 72°±60' (4-bit) EP: 36°±60' (1-bit)	
		40-division	TP1: 5°±60' (1-bit) TP2: 2°±60' (1-bit) TS: 9°±60' (6-bit) EP: 9°±60' (1-bit)	TP1: 5°±60' (1-bit) TP2: 2°±60' (1-bit) TS: 9°±60' (6-bit) EP: 9°±60' (1-bit)	TP1: 5°±60' (1-bit) TP2: 2°±60' (1-bit) TS: 18°±60' (6-bit) EP: 9°±60' (1-bit)					
		32-division	TP1: 7°±60' (1-bit) TP2: 2°±60' (1-bit) TS: 11.25°±60' (6-bit) EP: 11.25°±60' (1-bit)	TP1: 7°±60' (1-bit) TP2: 2°±60' (1-bit) TS: 11.25°±60' (5-bit) EP: 11.25°±60' (1-bit)	TP1: 7°±60' (1-bit) TP2: 2°±60' (1-bit) TS: 22.5°±60' (5-bit) EP: 11.25°±60' (1-bit)					
		24-division	TP1: 8°±60' (1-bit) TP2: 3°±60' (1-bit) TS: 15°±60' (6-bit) EP: 15°±60' (1-bit)	TP1: 8°±60' (1-bit) TP2: 3°±60' (1-bit) TS: 15°±60' (5-bit) EP: 15°±60' (1-bit)	TP1: 8°±60' (1-bit) TP2: 3°±60' (1-bit) TS: 30°±60' (5-bit) EP: 15°±60' (1-bit)	6-division	TP1: 53°±60' (1-bit) TP2: 15°±60' (1-bit) TS: 60°±60' (3-bit) EP: 60°±60' (1-bit)	TP1: 53°±60' (1-bit) TP2: 15°±60' (1-bit) TS: 60°±60' (3-bit) EP: 60°±60' (1-bit)	TP1: 53°±60' (1-bit) TP2: 15°±60' (1-bit) TS: 120°±60' (3-bit) EP: 60°±60' (1-bit)	
		Control output	PNP open collector output	Output voltage: Min. (power supply-1.5)VDC, Load current: Max. 32mA						
			NPN open collector output	Load current: Max. 32mA, Residual voltage: Max. 1VDC						
Response time (rise/fall)	Ton=800nsec, Toff=Max. 800nsec (cable length: 2m, I sink = 32mA)									
Max. response frequency	35kHz									
Power supply	• 5VDC ±5% (ripple P-P: max. 5%) • 12-24VDC ±5% (ripple P-P: max. 5%)									
Current consumption	Max. 100mA (disconnection of the load)									
Insulation resistance	Over 100MΩ (at 500VDC megger between all terminals and case)									
Dielectric strength	750VAC 50/60Hz for 1 minute (between all terminals and case)									
Connection	Axial cable type (cable gland)									

*1: TS=Signal Pulse, TP=Timing Pulse, EP=Even Parity

Absolute Ø50mm Shaft Type

Specifications

Item	Shaft Type Ø50mm Absolute Rotary Encoder	
Mechanical specification	Starting torque	Max. 40gf·cm (0.004N·m)
	Moment of inertia	Max. 40g·cm ² (4×10 ⁻⁶ kg·m ²)
	Shaft loading	Radial: 10kgf, Thrust: 2.5kgf
	Max. allowable revolution ^{※2}	3,000rpm
Vibration	1.5mm amplitude at frequency of 10 to 55Hz (for 1 min) in each X, Y, Z direction for 2 hours	
Shock	Approx. max. 50G	
Environment	Ambient temperature	-10 to 70°C, storage: -25 to 85°C
	Ambient humidity	35 to 85%RH, storage: 35 to 90%RH
Protection structure	IP64 (IEC standard)	
Cable	Ø7mm, 15-wire, 2m, Shield cable (AWG28, core diameter: 0.08mm, number of cores: 40, insulator out diameter: Ø0.8mm)	
Accessory	Fixing bracket, Coupling	
Approval	CE	
Unit weight	Approx. 380g	

※2: Make sure that max. response revolution should be lower than or equal to max. allowable revolution when selecting the resolution.

$$[\text{Max. response revolution (rpm)}] = \frac{\text{Max. response frequency}}{\text{Resolution}} \times 60 \text{ sec}$$

※Environment resistance is rated at no freezing or condensation.

Output Waveform

24-division (BCD code output)

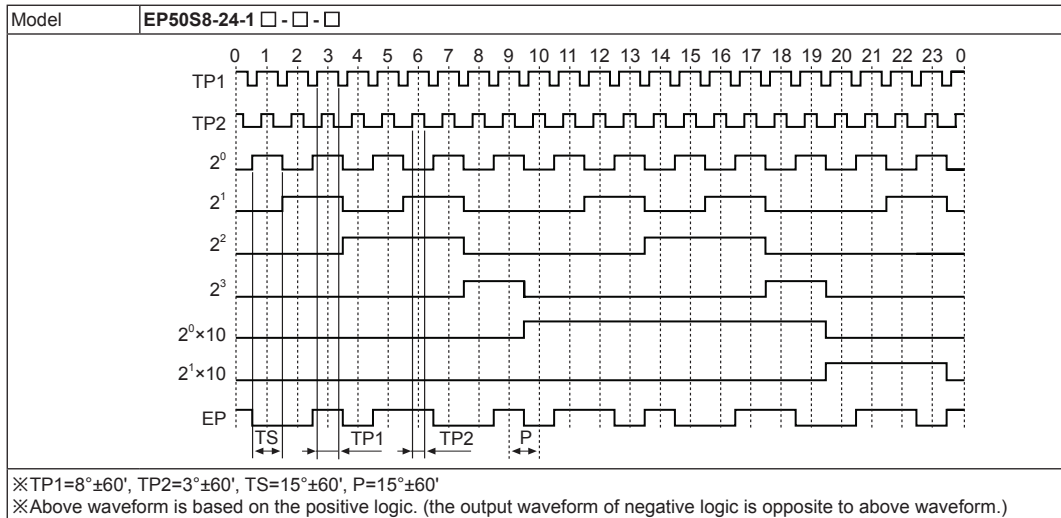

24-division (Binary code output)

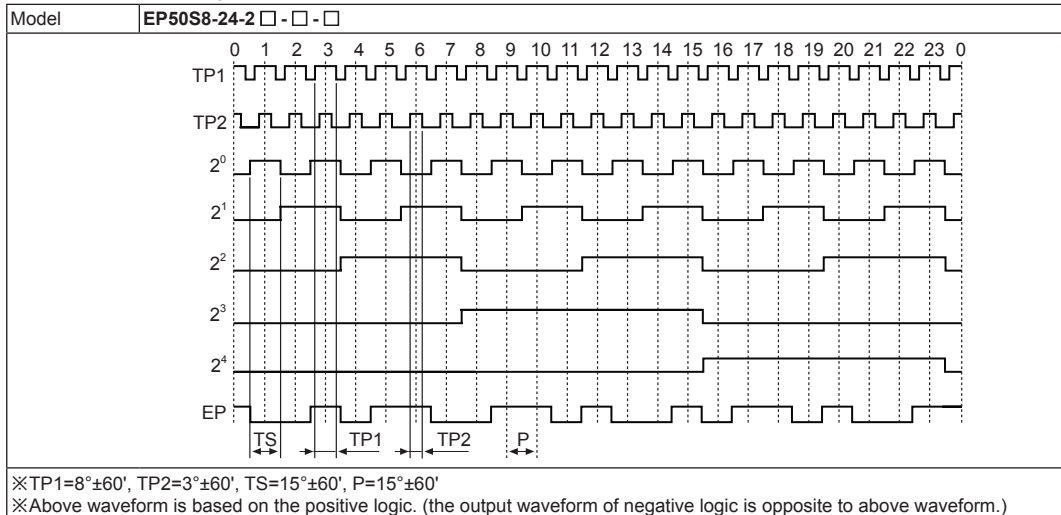

(A) Photoelectric Sensors

(B) Fiber Optic Sensors

(C) Door/Area Sensors

(D) Proximity Sensors

(E) Pressure Sensors

(F) Rotary Encoders

(G) Connectors/ Connector Cables/ Sensor Distribution Boxes/Sockets

(H) Temperature Controllers

(I) SSRs / Power Controllers

(J) Counters

(K) Timers

(L) Panel Meters

(M) Tacho / Speed / Pulse Meters

(N) Display Units

(O) Sensor Controllers

(P) Switching Mode Power Supplies

(Q) Stepper Motors & Drivers & Controllers

(R) Graphic/ Logic Panels

(S) Field Network Devices

(T) Software

EP50S Series

Output Waveform

• 360-division (BCD code output)

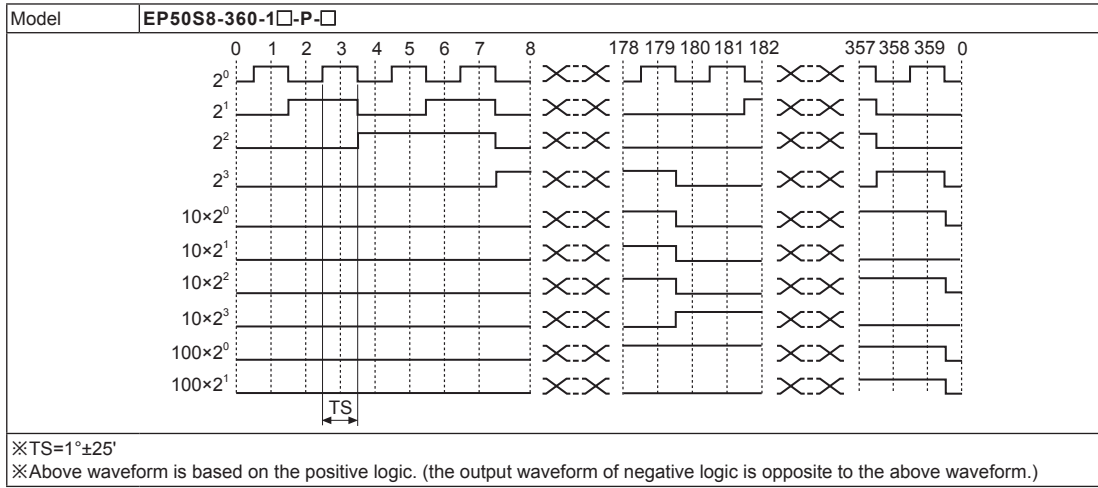

• 360-division (Binary code output)

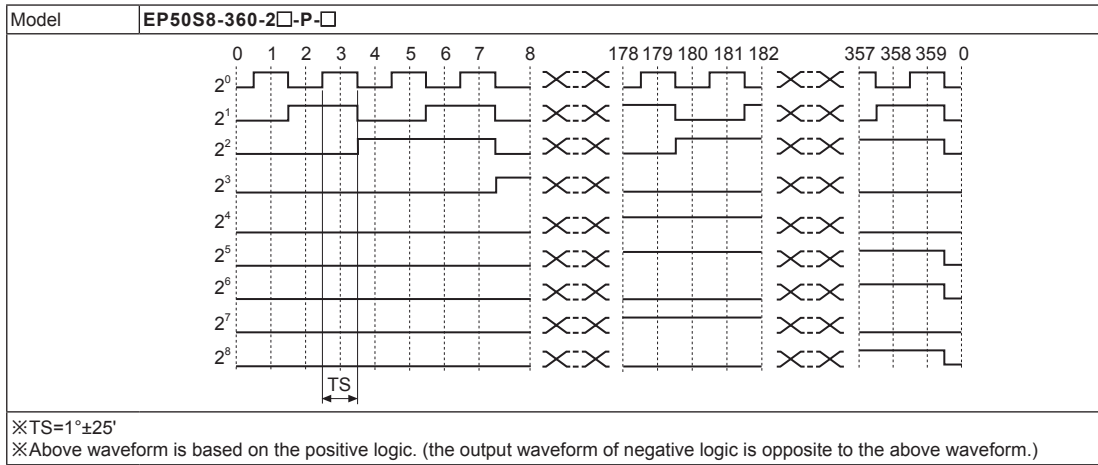

• 1024-division (BCD code output)

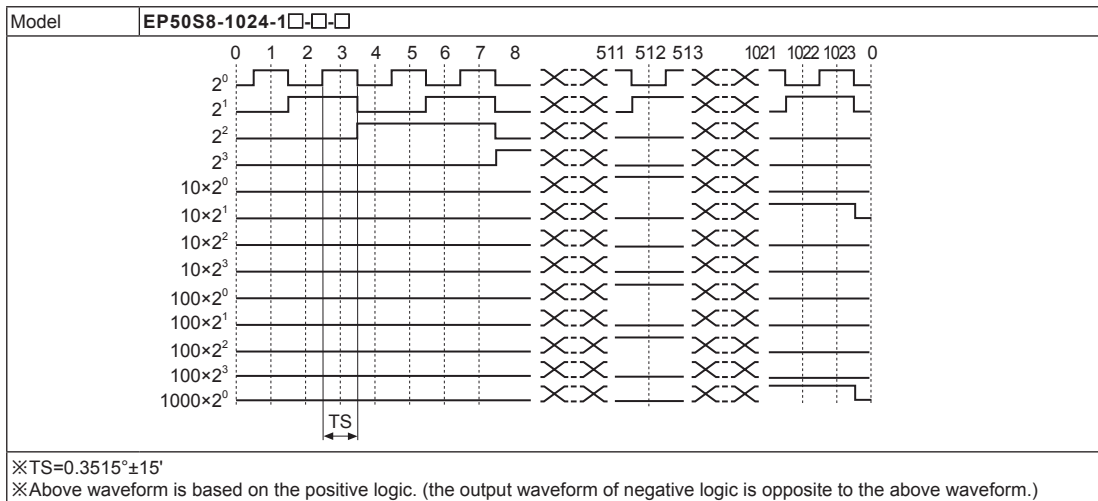

Absolute Ø50mm Shaft Type

Output Waveform

• 1024-division (Binary code output)

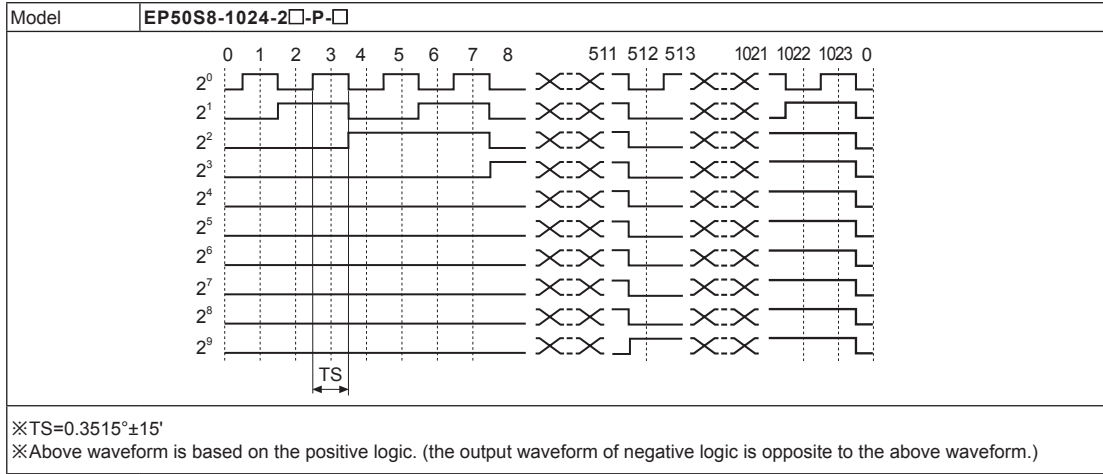

Control Output Diagram

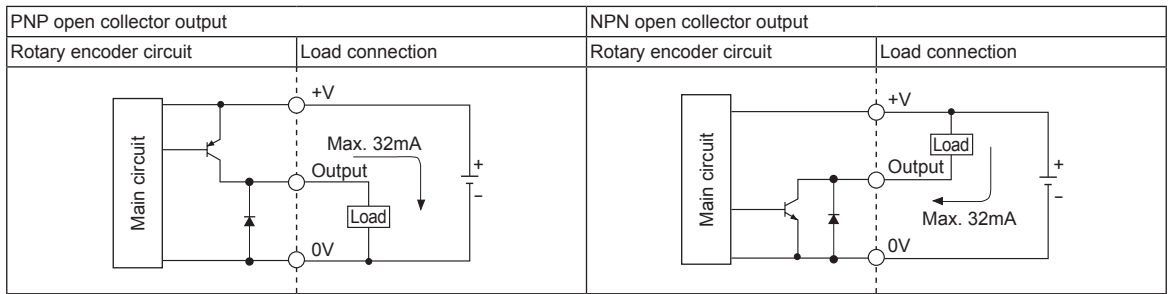

※Output circuits of all phases are same.

Connections

• BCD Code

Color	Resolution	6-division	8-division	10-division	12-division	16-division	20-division	24-division	32-division	40-division	45-division	48-division	64-division	90-division	128-division	180-division	256-division	360-division	512-division	720-division	1024-division		
	Power	White	+V																				
	Black	0V																					
Output wire	Brown	2 ⁰																					
	Red	2 ¹																					
	Orange	2 ²																					
	Yellow	N-C		2 ³																			
	Blue	N-C			2 ⁹ ×10																		
	Purple	N-C							2 ¹ ×10														
	Gray	N-C											2 ² ×10										
	White/Brown	TP1											N-C										2 ³ ×10
	White/Red	TP2											N-C										2 ⁰ ×10
	White/Orange	EP											N-C										2 ¹ ×100
	White/Yellow	N-C											N-C										2 ² ×100
	White/Blue	N-C											N-C										2 ³ ×100
	White/Purple	N-C											N-C										2 ⁰ ×1000
	Shield wire	F.G.																					

※Unused wires must be insulated.

※Encoder case and shield wire must be grounded (F.G.).

※N-C: Not Connected.

※Each output cable must not be short-circuited, because Driver IC is used in output circuit.

(A) Photoelectric Sensors

(B) Fiber Optic Sensors

(C) Door/Area Sensors

(D) Proximity Sensors

(E) Pressure Sensors

(F) Rotary Encoders

(G) Connectors/ Connector Cables/ Sensor Distribution Boxes/Sockets

(H) Temperature Controllers

(I) SSRs / Power Controllers

(J) Counters

(K) Timers

(L) Panel Meters

(M) Tacho / Speed / Pulse Meters

(N) Display Units

(O) Sensor Controllers

(P) Switching Mode Power Supplies

(Q) Stepper Motors & Drivers & Controllers

(R) Graphic/ Logic Panels

(S) Field Network Devices

(T) Software

EP50S Series

■ Connections

● Binary code/Gray code

Resolution		6-division	8-division	10-division	12-division	16-division	20-division	24-division	32-division	40-division	45-division	48-division	64-division	90-division	128-division	180-division	256-division	360-division	512-division	720-division	1024-division	
Power	White	+V																				
	Black	0V																				
Output wire	Brown	2 ⁰																				
	Red	2 ¹																				
	Orange	2 ²																				
	Yellow	N-C		2 ³																		
	Blue	N-C			2 ⁴																	
	Purple	N-C						2 ⁵														
	Gray	N-C										2 ⁶										
	White/Brown	TP1										N-C					2 ⁷					
	White/Red	TP2										N-C					2 ⁸					
	White/Orange	EP										N-C					2 ⁹					
	Shield wire	F.G.																				

※Unused wires must be insulated.

※Encoder metal case and shield wire must be grounded (F.G.).

※N-C: Not Connected.

※Each output cable must not be short-circuited, because Driver IC is used in output circuit.

■ Dimensions

(unit: mm)

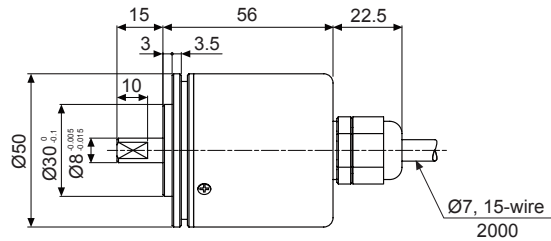
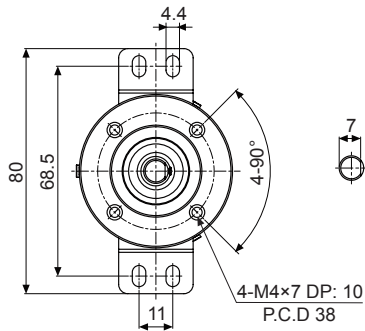

● Bracket

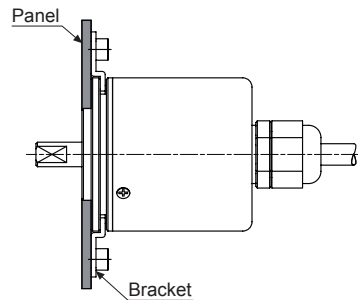
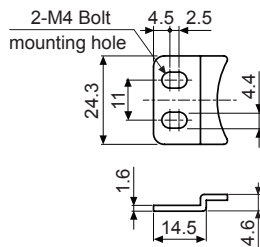

● Coupling (EP50S)

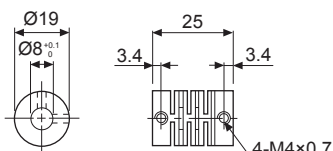

- Parallel misalignment: Max. 0.25mm
- Angular misalignment: Max. 5°
- End-play: Max. 0.5mm

※For parallel misalignment, angular misalignment, end-play terms, refer to page F-87.

※For flexible coupling (ERB series) information, refer to page F-80.