

E30S Series

Shaft Type Ø30mm Incremental Rotary Encoder

■ Features

- Ø30mm of miniature shaft type rotary encoder
- Easy installation at narrow space
- Low moment of inertia
- Power supply: 5VDC, 12-24VDC ±5%
- Various output types



⚠ Please read "Caution for your safety" in operation manual before using.



■ Ordering Information

E30S	4	—	3000	—	3	—	N	—	24	—	
Series	Shaft diameter	Pulses/revolution	Output phase	Control output	Power supply	Cable					
Ø30mm, shaft type	Ø4mm	Refer to resolution	3: A, B, Z 6: A, \bar{A} , B, \bar{B} , Z, \bar{Z}	T: Totem pole output N: NPN open collector output V: Voltage output L: Line driver output (※)	5: 5VDC ±5% 24: 12-24VDC ±5%	No mark: Axial cable type C: Axial cable connector type					

※The power of Line driver is only for 5VDC.

■ Specifications

Item		Shaft type Ø30mm Incremental Rotary Encoder	
Resolution (PPR) ^{※1}		100, 200, 360, 500, 1000, 1024, 3000	
Electrical specification	Output phase		A, B, Z phase (line driver: A, \bar{A} , B, \bar{B} , Z, \bar{Z} phase)
	Phase difference of output		Phase difference between A and B: $\frac{T}{4} \pm \frac{T}{8}$ (T=1 cycle of A phase)
	Control output	Totem pole output	• [Low] - Load current: Max. 30mA, Residual voltage: Max. 0.4VDC • [High] - Load current: Max. 10mA, Output voltage (power voltage 5VDC): Min. (power voltage-2.0)VDC, Output voltage (power voltage 12-24VDC): Min. (power voltage-3.0)VDC
		NPN open collector output	Load current: Max. 30mA, Residual voltage: Max. 0.4VDC
		Voltage output	Load current: Max. 10mA, Residual voltage: Max. 0.4VDC
		Line driver output	• [Low] - Load current: Max. 20mA, Residual voltage: Max. 0.5VDC • [High] - Load current: Max. -20mA, Output voltage: Min. 2.5VDC
	Response time (rise/fall)	Totem pole output	Max. 1μs (cable length: 2m, I sink = 20mA)
		NPN open collector output	
		Voltage output	
	Line driver output	Max. 0.5μs (cable length: 2m, I sink = 20mA)	
	Max. Response frequency		300kHz
	Power supply		• 5VDC ±5% (ripple P-P: Max. 5%) • 12-24VDC ±5% (ripple P-P: Max. 5%)
	Current consumption		Max. 80mA (disconnection of the load), Line driver output: Max. 50mA (disconnection of the load)
	Insulation resistance		Over 100MΩ (at 500VDC megger between all terminals and case)
Dielectric strength		750VAC 50/60Hz for 1 minute (between all terminals and case)	
Connection		Axial cable type, Axial cable connector type	
Mechanical specification	Starting torque		Max. 20gf·cm (0.002N·m)
	Moment of inertia		Max. 20g·cm ² (2×10 ⁻⁶ kg·m ²)
	Shaft loading		Radial: Max. 2kgf, Thrust: Max. 1kgf
	Max. allowable revolution ^{※2}		5,000rpm
	Vibration		1.5mm amplitude at frequency of 10 to 55Hz (for 1 min) in each X, Y, Z direction for 2 hours
Shock		Approx. Max. 50G	
Environment	Ambient temperature	-10 to 70°C, storage: -25 to 85°C	
	Ambient humidity	35 to 85%RH, storage: 35 to 90%RH	
Protection structure		IP50 (IEC standard)	
Cable		Ø5mm, 5-wire (line driver: Ø5mm, 8-wire), 2m, Shield cable (AWG24, core diameter: 0.08mm, number of cores: 40, insulator out diameter: Ø1mm)	
Accessory		Ø4mm coupling	
Approval		CE (except line driver output)	
Unit weight		Approx. 80g	

※1: Not indicated resolutions are customizable.

※Environment resistance is rated at no freezing or condensation.

※2: Make sure that max. response revolution should be lower than or equal to max. allowable revolution when selecting the resolution.

$$[\text{Max. response revolution (rpm)}] = \frac{\text{Max. response frequency}}{\text{Resolution}} \times 60 \text{ sec}]$$

Incremental Ø30mm Shaft Type

Control Output Diagram

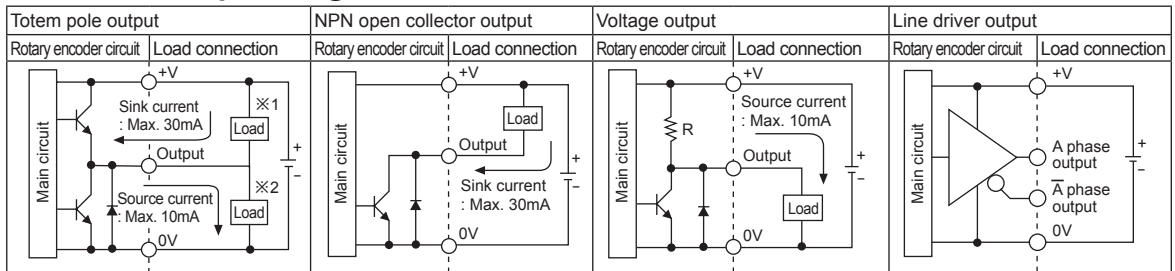

- Totem pole output type can be used for NPN open collector output type (※1) or Voltage output type (※2).
- All output circuits of A, B, Z phase are same. (line driver output is for A, \bar{A} , B, \bar{B} , Z, \bar{Z})

Output Waveform

Totem pole output / NPN open collector output / Voltage output

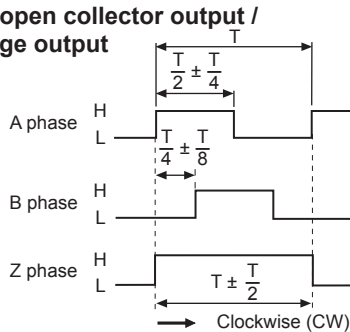

Line driver output

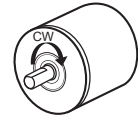
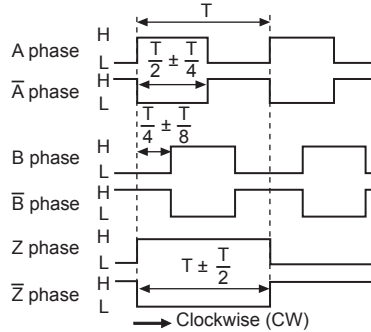

Connections

◎ Cable type

Totem pole output / NPN open collector output / Voltage output



Line driver output

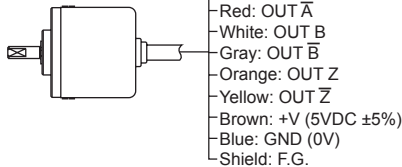

- ※ Unused wires must be insulated.
- ※ The metal case and shield wire of encoder should be grounded (F.G.).

◎ Connector cable type

Totem pole output / NPN open collector output / Voltage output

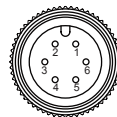

Line driver output

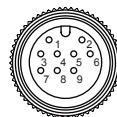

Totem pole output NPN open collector output Voltage output			Line driver output		
Pin No	Function	Cable color	Pin No	Function	Cable color
①	OUT A	Black	①	OUT A	Black
②	OUT B	White	②	OUT \bar{A}	Red
③	OUT Z	Orange	③	+V	Brown
④	+V	Brown	④	GND	Blue
⑤	GND	Blue	⑤	OUT B	White
⑥	F.G.	Shield	⑥	OUT \bar{B}	Gray
			⑦	OUT Z	Orange
			⑧	OUT \bar{Z}	Yellow
			⑨	F.G.	Shield

※ F.G. (field ground): It should be grounded separately.

Dimensions

◎ Axial cable type

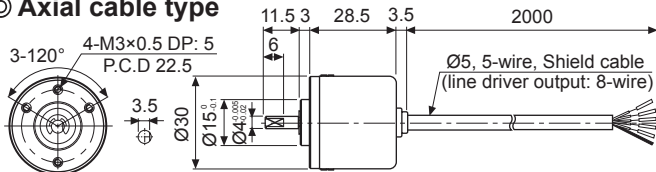

• Coupling (E30S)

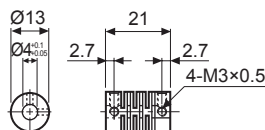

- Parallel misalignment: Max. 0.25mm
- Angular misalignment: Max. 5°
- End-play: Max. 0.5mm
- ※ Do not load overweight on the shaft.
- ※ For parallel misalignment, angular misalignment, end-play terms, refer to page F-87.
- ※ For flexible coupling (ERB series) information, refer to page F-80.
- ※ When mounting the coupling to the encoder shaft, if there is combined misalignment (parallel, angular misalignment) between rotating encoder shaft and mate shaft, it may cause encoder and coupling's life cycle to shorten.

◎ Axial cable connector type

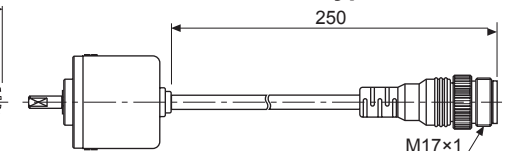

※ Connector cable is sold separately and refer to page G-10 for specifications.

(A) Photoelectric Sensors

(B) Fiber Optic Sensors

(C) Door/Area Sensors

(D) Proximity Sensors

(E) Pressure Sensors

(F) Rotary Encoders

(G) Connectors/ Connector Cables/ Sensor Distribution Boxes/Sockets

(H) Temperature Controllers

(I) SSRs / Power Controllers

(J) Counters

(K) Timers

(L) Panel Meters

(M) Tacho / Speed / Pulse Meters

(N) Display Units

(O) Sensor Controllers

(P) Switching Mode Power Supplies

(Q) Stepper Motors & Drivers & Controllers

(R) Graphic/ Logic Panels

(S) Field Network Devices

(T) Software