

Small Emitter/Receiver Synchronizing Type

■ Features

- Small size: W12×H30×L16mm
- Minimize malfunction by extraneous light by synchronizing emitter and receiver
- Built-in reverse polarity protection circuit, output overcurrent (short-circuit) protection circuit
- Fast response speed: Max. 1ms

 Please read "Caution for your safety" in operation manual before using.

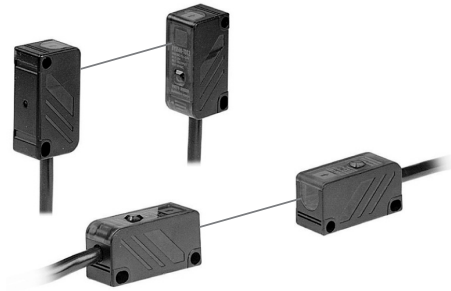

■ Specifications

Model	Standard type	Side sensing type
	BY500-TDT	BYS500-TDT
Sensing type	Through-beam	
Sensing distance	500mm	
Sensing target	Opaque materials of min. Ø5mm	
Response time	Max. 1ms	
Power supply	12-24VDC ±10% (ripple P-P: max. 10%)	
Current consumption	Max. 30mA	
Light source	Infrared LED (940nm)	
Operation mode	Dark ON	
Control output	NPN open collector output • Load voltage: 30VDC • Load current: Max. 100mA • Residual voltage: Max. 1V	
Protection circuit	Reverse polarity protection circuit, output overcurrent (short-circuit) protection circuit	
Indicator	Operation indicator: red LED	
Insulation resistance	Over 20MΩ (at 500VDC megger)	
Noise immunity	±240V the square wave noise (pulse width: 1μs) by the noise simulator	
Dielectric strength	1,000VAC 50/60Hz for 1minute	
Vibration	1.5mm amplitude at frequency of 10 to 55Hz (for 1 min) in each X, Y, Z direction for 2 hours	
Shock	500m/s ² (approx. 50G) in each X, Y, Z direction for 3 times	
Environment	Ambient illumination	Sunlight: Max. 11,000lx Incandescent lamp: Max. 3,000 lx (receiving illumination)
	Ambient temperature	-10 to 60°C, storage: -25 to 70°C
	Ambient humidity	35 to 85%RH, storage: 35 to 85%RH
Protection structure	IP50 (IEC standard)	
Material	Case: Acrylonitrile butadiene styrene, Sensing part: Acrylic, Bracket: Steel plate cold commercial, Bolt: Steel chromium molybdenum, Nut: Steel chromium molybdenum	
Cable	Ø4mm, 4-wire, 2m (emitter of through-beam type: Ø4mm, 3-wire, 2m) (AWG22, core diameter: 0.08mm, number of cores: 60, insulator out diameter: Ø1.25mm)	
Accessories	Fixing bracket, Bolts, Nuts	
Unit weight	Approx. 150g	

※The temperature or humidity mentioned in Environment indicates a non freezing or condensation environment.

(A) Photoelectric Sensors

(B) Fiber Optic Sensors

(C) Door/Area Sensors

(D) Proximity Sensors

(E) Pressure Sensors

(F) Rotary Encoders

(G) Connectors/ Connector Cables/ Sensor Distribution Boxes/ Sockets

(H) Temperature Controllers

(I) SSRs / Power Controllers

(J) Counters

(K) Timers

(L) Panel Meters

(M) Tacho / Speed / Pulse Meters

(N) Display Units

(O) Sensor Controllers

(P) Switching Mode Power Supplies

(Q) Stepper Motors & Drivers & Controllers

(R) Graphic/ Logic Panels

(S) Field Network Devices

(T) Software

BY Series

Feature Data

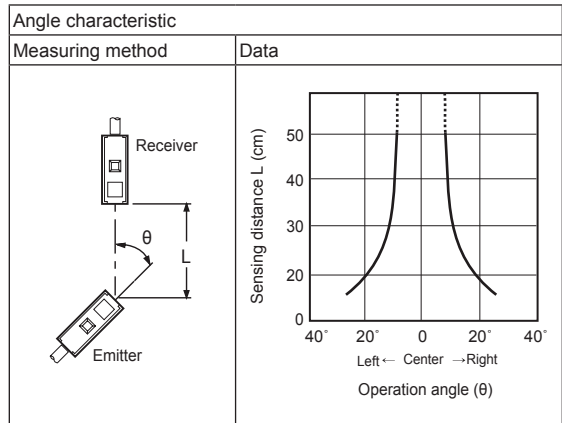
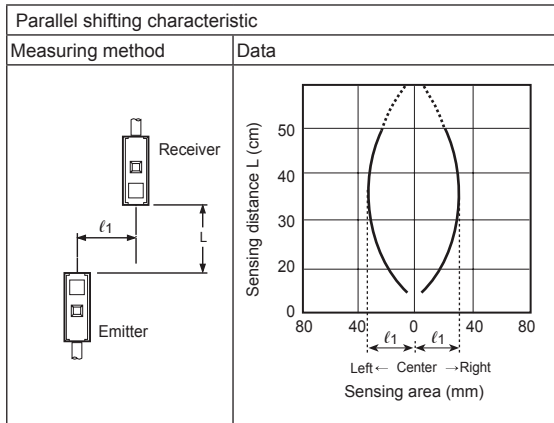

Control Output Diagram

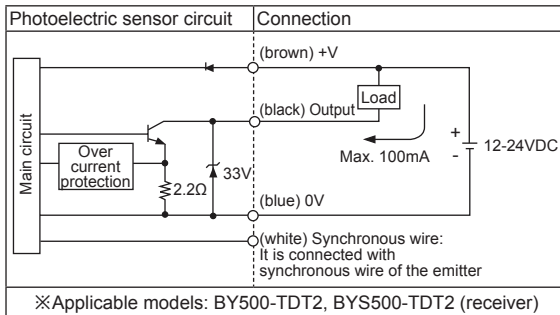

Operation Mode

Operation mode	Dark ON
Receiver operation	<p>Received light</p> <p>Interrupted light</p>
Operation indicator (red LED)	<p>ON</p> <p>OFF</p>
Transistor output	<p>ON</p> <p>OFF</p>

※If the control output terminal is short-circuited or overcurrent condition exists, the control output turns OFF due to protection circuit.

※Please supply the power to the brown and the blue wires of the emitter and Synchronous wire (white) of the receiver must be connected with that of the emitter.

Connections

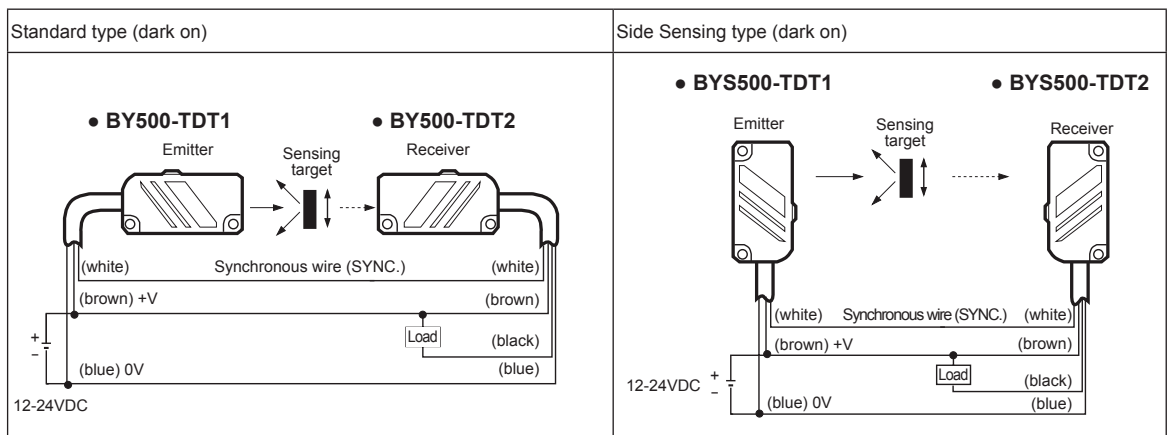

※The power of the emitter and the receiver must be supplied from the same power line.

※Synchronous wire (white) of the receiver must be connected with that of the emitter, or it may cause malfunction.

Small And Amplifier Built-in Type

■ Dimensions

(unit: mm)

● BY500-TDT

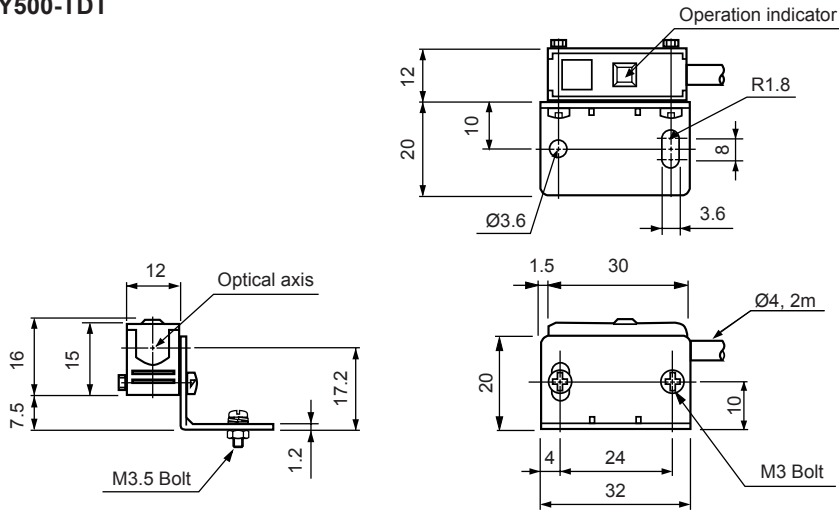

● BY500-TDT

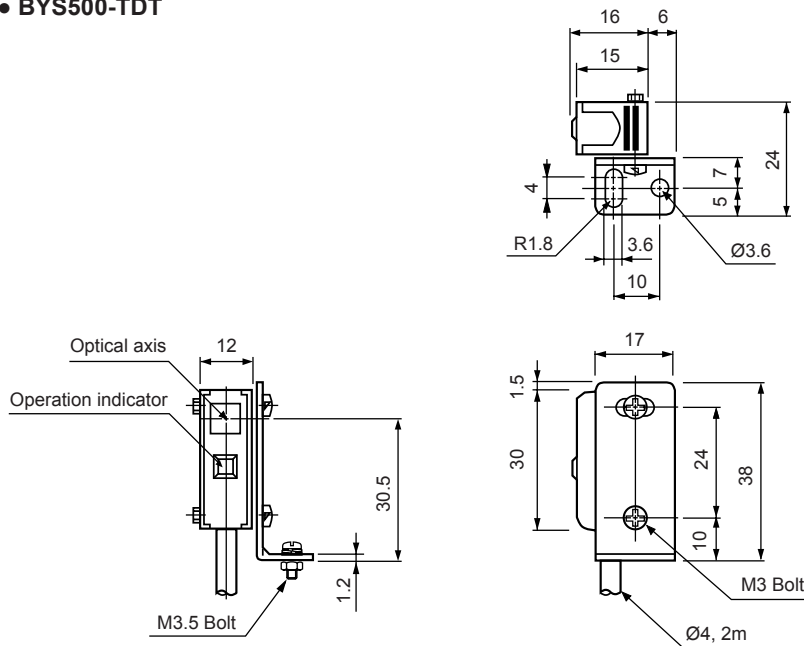

■ Mounting And Sensitivity Adjustment

1. Supply the power to the sensor, after installing the emitter and the receiver facing each other.
 2. Set the receiver in the middle of position where the operation indicator turns ON adjusting the receiver to the right and the left or up and down.
 3. Fix both units tightly after checking that the unit detects the target.
- ※If a sensing target is translucent body or smaller than Ø5mm, it might not be detected because the because light penetrate it.

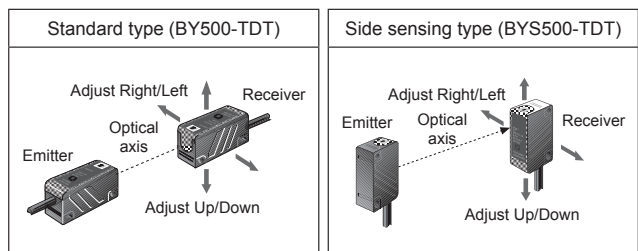

(A)
Photoelectric
Sensors

(B)
Fiber
Optic
Sensors

(C)
Door/Area
Sensors

(D)
Proximity
Sensors

(E)
Pressure
Sensors

(F)
Rotary
Encoders

(G)
Connectors/
Connector Cables/
Sensor Distribution
Boxes/ Sockets

(H)
Temperature
Controllers

(I)
SSRs / Power
Controllers

(J)
Counters

(K)
Timers

(L)
Panel
Meters

(M)
Tacho /
Speed / Pulse
Meters

(N)
Display
Units

(O)
Sensor
Controllers

(P)
Switching
Mode Power
Supplies

(Q)
Stepper Motors
& Drivers
& Controllers

(R)
Graphic/
Logic
Panels

(S)
Field
Network
Devices

(T)
Software