

2D Laser Scanners



LSE2 Series CATALOG

For your safety, read and follow the considerations written in the instruction manual, other manuals and Autonics website.

The specifications, dimensions, etc. are subject to change without notice for product improvement. Some models may be discontinued without notice.

Major Features

- 90° detection angle, 5.6 × 5.6 m detection range
- Compact size for flexible installation (W 120 × H 47.5 × L 89.4 mm)
- Various filter function to prevent malfunction due to fog, rain, snow and dusts
- Operation indicator to identify operation status and errors
: check status even in unstable conditions or change in installation location
- Ethernet communication supported
- Dedicated software atLiDAR provided
: PC, Mobile (Android)

Product Components

- Product
- Instruction manual

Software

Download the installation file and the manuals from the Autonics website. Supported devices are different for each software version.

■ atLiDAR (PC, V2.1 or later)

atLiDAR is the management program for laser scanner parameter settings, status information and monitoring data, etc.

This program communicates with the laser scanner via Ethernet communication.

■ atLiDAR (mobile)

atLiDAR is Android only mobile application that can manage monitoring data such as laser scanner parameter settings and status information.

Connect the laser scanner with atLiDAR by connecting the USB-C to Ethernet gender.

Specifications

Model	LSE2-A5R2-ET
Laser for detection emitting property	Infrared laser: 1
Laser class	CLASS 1
Wave length band	905 nm
Max. pulse output power	27 W
Laser for installation emitting property	Visible light laser: 2
Laser class	CLASS 3R
Wave length band	650nm
Max. CW ⁰¹⁾ output power	4 mW
Min. object size ⁰²⁾	OFF, 5, 8, 10, 15, 20, 25, 30, 35, 40 cm
Scanning frequency	25 Hz
Response time	≤ 50 ms + monitoring time
Monitoring zone ⁰³⁾	≤ 5.6 × 5.6 m
Angular resolution	0.25°
Aperture angle	90°
Object reflectivity ⁰⁴⁾	≥ 2 %
Approval	CE
Korean Railway Standards	KRS SG 0068
Unit weight (package)	≈ 0.8 kg (≈ 1 kg)

01) Continuous wave

02) It is based on a white reflector.

Even objects smaller than the set min. object size can be detected depending on the environment.

03) At detection distance: 4 m, object reflectivity: 5 %, fog filter level: 0

04) At detection distance: 1.5 m, fog filter level: 0, object size = W 700 × H 300 × L 200 mm

Power supply	24 VDC± ± 15 %
Power consumption	< 10 W
Input	Photocoupler input: 1 H ⁰¹⁾ : ≥ 8 - 30 VDC±, L: ≤ 3 VDC±
Output	PhotoMOS relay output: 2 Resistive load: 30 VDC± / 24 VAC~, ≤ 80 mA
Vibration	2 G
Shock	30 G / 18 ms
Ambient illuminance	Sunlight: ≤ 100,000 lx
Ambient temperature	-30 to 60 °C, storage: -30 ~ 70 °C (no freezing or condensation)
Ambient humidity	0 to 95 %RH, storage: 0 to 95 %RH (no freezing or condensation)
Protection structure	IP67 (IEC standard)
Cable spec.	Power I / O cable: Ø 5 mm, 8-wire, 5 m Ethernet cable: Ø 5 mm, 4-wire, 3 m, shield cable, RJ45 connector
Wire spec.	AWG26 (0.16 mm, 7-core), insulator outer diameter: Ø 1 mm
Material	Case: AL, Window: PC

01) Operates as output test mode and outputs obstacle detection output and error status output.

Communication Interface

■ Ethernet

Communication protocol	TCP/IP
Communication speed	10BASE-TX
Baud rate	10Mbps

Dimensions

- Unit: mm, For the detailed drawings, follow the Autonics website.

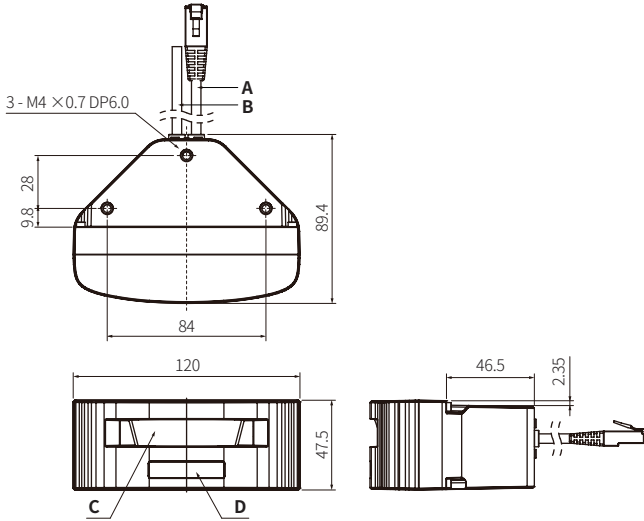

A	Ethernet cable	C	Window of laser for detection
B	Power I/O cable	D	Indicators (1, 2), laser for installation

Sold Separately

- Main bracket: BK-LSE2
- Sub bracket: BK-LSE2-SUB

Sold Separately: Bracket

- Unit: mm, For the detailed drawings, follow the Autonics website.

■ Main bracket: BK-LSE2

- Components: M4 × L8 bolt: 3, M4 × L10 bolt: 2

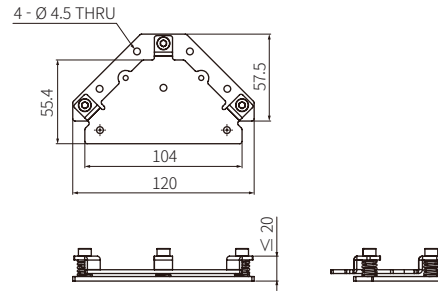

■ Sub bracket: BK-LSE2-SUB

- Components: M4 × L8 bolt: 4

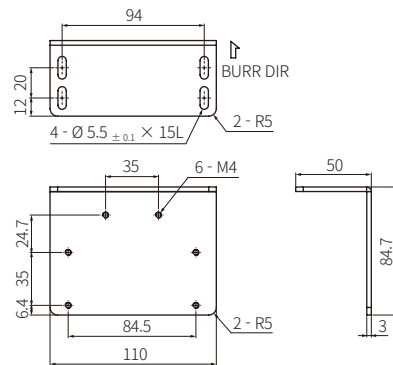

■ Main / sub bracket mounting

The device can be installed according to the desired installation angle by connecting 4 - Ø 4.5 through holes of the main bracket and 4 consecutive M4 holes of the sub bracket.

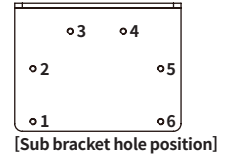

When mounting M4 hole 1-2-3-4	When mounting M4 hole 2-3-4-5	When mounting M4 hole 3-4-5-6