

## Auto Door Sensor

### ■ Features

- Adjustable hold time switch (2, 7, 15 seconds)
- 4-step detection angle adjustment (7.5°, 14.5°, 21.5°, 28.5°)
- Adjustable detection area (left/right area elimination)
- Max. detection area: 2460 mm x 86 mm (height 2.7 m)
- Wide range power supply:  
24-240 VAC / 24-240 VDC (universal AC/DC type),  
12-24 VAC / 12-24 VDC (universal AC/DC type)
- Built-in microprocessor



**⚠ Please read "Caution for your safety" in operation manual before using.**

### ■ Specifications

Model	ADS-AF	ADS-AE
Cover color	Silver	
Power supply	24-240VAC ±10% 50/60Hz, 24-240VDC ±10% (ripple P-P: max. 10%)	12-24VAC ±10% 50/60Hz, 12-24VDC ±10% (ripple P-P: max. 10%)
Power consumption	Max. 4VA (at 240VAC)	Max. 2VA (at 24VAC)
Control output	Contact type	1a
	Contact capacity※1	50VDC 0.1A (resistive load)
Relay life cycle	Mechanical: Min. 20,000,000 times, Electrical: Min. 50,000 times	
Mounting height	2.0m to 2.7m (max. sensing distance: 3.0m)	
Sensing method	Infrared reflection method	
Sensing area	9 Point (refer to the below chart)	
Output holding time	Time delay approx. 0.5sec	
Holding time of stationary sensing	Selectable 2sec, 7sec, 15sec (selectable by holding time setting switch)	
Interference prevention	H, L (selectable by interference prevention switch)	
Front sensing area	7.5°, 14.5°, 21.5°, 28.5°: 4 steps variable (adjusting by angle adjuster)	
Adjustable sensing area	(1, 2, 3 area), (7, 8, 9 area) Eliminate each by each : Adjusting with eliminating right/left sensing area lever	
Light source	Infrared emitting diode (modulated)	
Indicator	Operation indicator: Orange LED, Green LED, Red LED (refer to C-8 for the display status in operation)	
Connection method	Connector wire connection	
Insulation resistance	Over 20MΩ (at 500VDC megger)	
Noise immunity	±2,000V the square wave noise (pulse width:1μs) by the noise simulator	
Dielectric strength	1,000VAC 50/60Hz for 1 minute	
Vibration	1.5mm amplitude at frequency of 10 to 55Hz in each X, Y, Z direction for 2 hours	
Shock	100m/s <sup>2</sup> (approx. 10G) in each X, Y, Z direction for 3 times	
Environment	Ambient illumination	Sunlight: Max. 3,000lx, Incandescent lamp: Max. 3,000lx (receiver illumination)
	Ambient temperature	-20°C to 50°C, storage: -20 to 70°C
	Ambient humidity	35 to 85%RH, storage: 35 to 85%RH
Accessory	Cable: 2.5m, Mounting screw: 2, Mounting template	
Protection structure	IP50 (IEC standard)	
Material	Case: Acrylonitrile butadiene styrene, Lens: Acryl, Lens cover: Acryl	
Unit weight	Approx. 320g	

※1: Do not use Load which is beyond the rated capacity of contact point of Relay.

It can cause bad insulation, contact fusion, bad contact, relay breakdown, and fire etc.

※The temperature or humidity mentioned in Environment indicates a non freezing or condensation environment.

(A) Photoelectric Sensors

(B) Fiber Optic Sensors

(C) Door/Area Sensors

(D) Proximity Sensors

(E) Pressure Sensors

(F) Rotary Encoders

(G) Connectors/ Connector Cables/ Sensor Distribution Boxes/ Sockets

(H) Temperature Controllers

(I) SSRs / Power Controllers

(J) Counters

(K) Timers

(L) Panel Meters

(M) Tacho / Speed / Pulse Meters

(N) Display Units

(O) Sensor Controllers

(P) Switching Mode Power Supplies

(Q) Stepper Motors & Drivers & Controllers

(R) Graphic/ Logic Panels

(S) Field Network Devices

(T) Software

## Unit Description

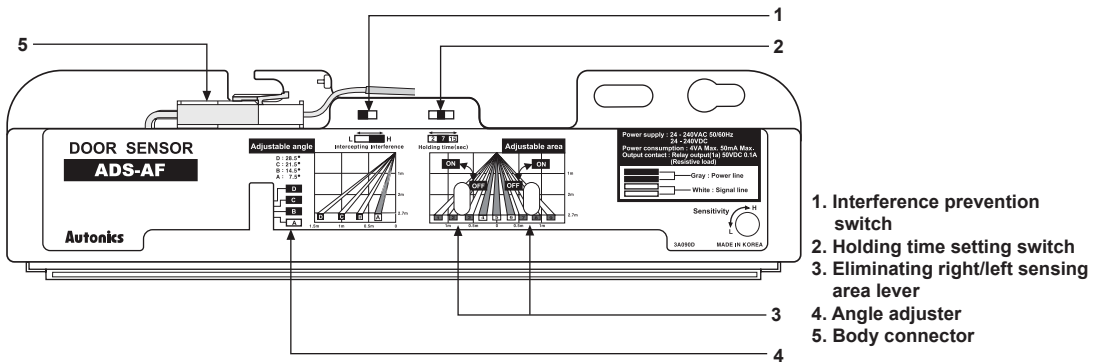

## Dimensions

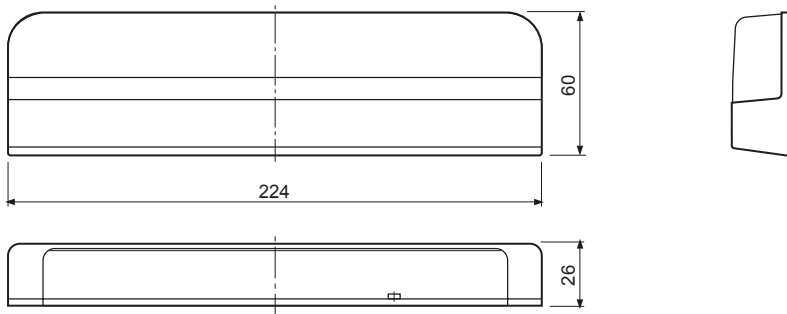

(unit: mm)

## Mounting Method

Installation order	⚠ Caution
<p><b>1. Attach mounting template at mounting position</b> (mounting height: 2.0m to 2.7m)</p> <ul style="list-style-type: none"> <li>• Drill Ø3.4mm hole based on mounting template.</li> <li>• In case of wiring the cable on the wall to hide the cable, drill Ø9mm hole.</li> <li>• Install the unit after removing the mounting template.</li> </ul> <p>Hole for inner cable connection</p> <p>Max. 2.7m</p> <p>Mounting hole</p> <p>Center</p> <p>Mounting template</p>	<p><b>⚠ Warning</b> It may cause electric shock.</p> <ul style="list-style-type: none"> <li>• When this unit is used with cable outlet removed from cover, it must be installed indoors. (Electric shock or damage can occur if water flows through cable outlet.)</li> </ul> <p><b>⚠ Caution</b> People can be jammed in the door.</p> <ul style="list-style-type: none"> <li>• If this unit is installed higher than 2.7m in height, it may not detect short children.</li> <li>• If this unit is installed lower than 2.0m in height, it may not work properly.</li> </ul>

## ■ Installation

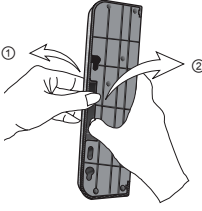
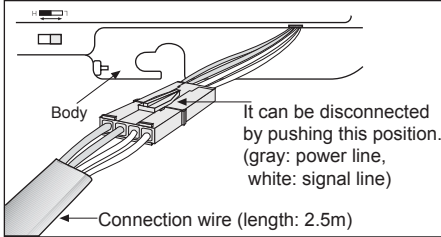
Installation order	⚠ Caution
<p><b>2. Please fix the unit with screws bolt after removing protection cover off.</b></p> 	<div style="background-color: #f0f0f0; padding: 5px; margin-bottom: 10px;"> <p><b>⚠ Caution Mounting the unit</b></p> </div> <ul style="list-style-type: none"> <li>Do not put excessive tightening torque on screw bolt when mounting this unit. It may result in mounting hole damage.</li> </ul> <p><b>&lt;How to remove protection cover&gt;</b></p> <ul style="list-style-type: none"> <li>Pulling left thumb toward ①, key lock will be released and pull right thumb toward ②, protection cover and body will be detached.</li> </ul>
<p><b>3. Connect the code part of the extension cable to main control part.</b></p> <ul style="list-style-type: none"> <li>Please install the connector in order to connect with the body.</li> </ul>	
<p><b>4. Connect the connector of the body and the connector of the extension cable.</b></p>  <p>It can be disconnected by pushing this position. (gray: power line, white: signal line)</p> <p>← Connection wire (length: 2.5m)</p>	<div style="background-color: #f0f0f0; padding: 5px; margin-bottom: 10px;"> <p><b>⚠ Caution Connection of the connector</b></p> </div> <ul style="list-style-type: none"> <li>Plug in the connector of the extension cable and the connector of the unit. The unit may not work normally by inferior contact.</li> </ul>

## ■ Adjustment

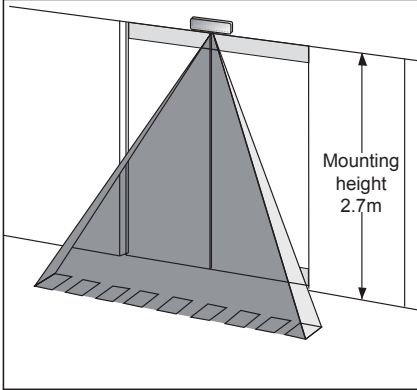
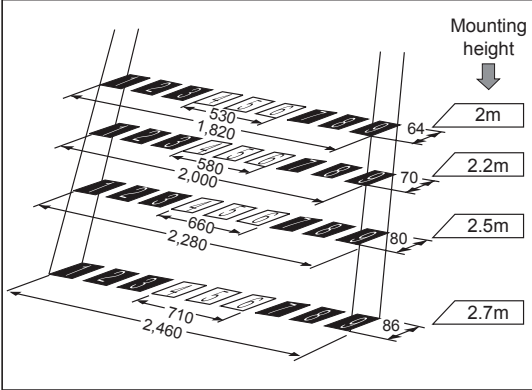
Please turn ON the power.											
<p><b>1. Check of the sensing area</b></p> <p>This unit has characteristic of the sensing area as below chart and figure.</p> 	<p style="text-align: right;">(unit: mm)</p>  <table border="1" style="margin-left: auto; margin-right: auto;"> <thead> <tr> <th>Mounting height</th> <th>Sensing Area Dimensions (mm)</th> </tr> </thead> <tbody> <tr> <td>2m</td> <td>530 (top), 1,820 (bottom)</td> </tr> <tr> <td>2.2m</td> <td>580 (top), 2,000 (bottom)</td> </tr> <tr> <td>2.5m</td> <td>660 (top), 2,280 (bottom)</td> </tr> <tr> <td>2.7m</td> <td>710 (top), 2,460 (bottom)</td> </tr> </tbody> </table>	Mounting height	Sensing Area Dimensions (mm)	2m	530 (top), 1,820 (bottom)	2.2m	580 (top), 2,000 (bottom)	2.5m	660 (top), 2,280 (bottom)	2.7m	710 (top), 2,460 (bottom)
Mounting height	Sensing Area Dimensions (mm)										
2m	530 (top), 1,820 (bottom)										
2.2m	580 (top), 2,000 (bottom)										
2.5m	660 (top), 2,280 (bottom)										
2.7m	710 (top), 2,460 (bottom)										

(A)	Photoelectric Sensors
(B)	Fiber Optic Sensors
(C)	Door/Area Sensors
(D)	Proximity Sensors
(E)	Pressure Sensors
(F)	Rotary Encoders
(G)	Connectors/ Connector Cables/ Sensor Distribution Boxes/ Sockets
(H)	Temperature Controllers
(I)	SSRs / Power Controllers
(J)	Counters
(K)	Timers
(L)	Panel Meters
(M)	Tacho / Speed / Pulse Meters
(N)	Display Units
(O)	Sensor Controllers
(P)	Switching Mode Power Supplies
(Q)	Stepper Motors & Drivers & Controllers
(R)	Graphic/ Logic Panels
(S)	Field Network Devices
(T)	Software

## Adjustment

### 2. Adjustable sensing area

Adjustable 7° in each step.

(sensing area angle step: 7.5° to 28.5°)

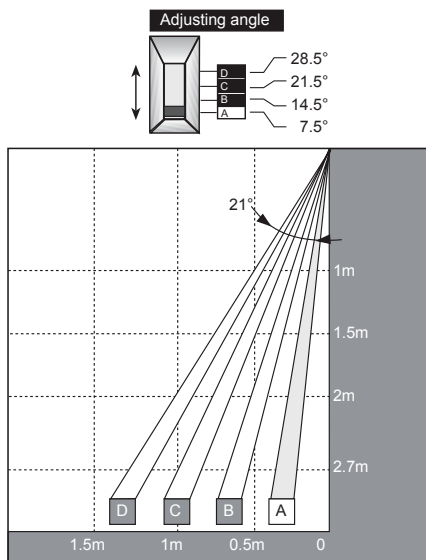

**⚠ Caution** People can be jammed in the door.

- The unit is not safety sensor. Install the fail-safe device before using the unit.

### 3. Adjustment of Left, Right sensing area width

Sensing area width [1], [2], [3] can be eliminated by left lever, 789 by right lever.

- Use the unit as removing non-sensing area by the lever adjusting width at narrow sensing area.

※ Turn the adjuster till it stops it toward arrow direction by a (-)driver.

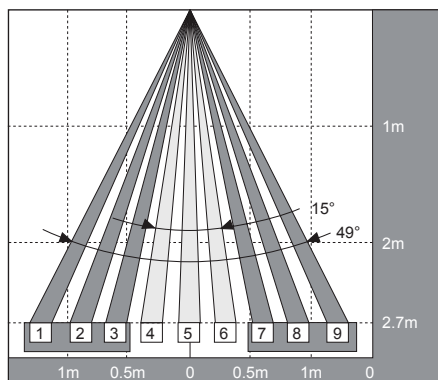
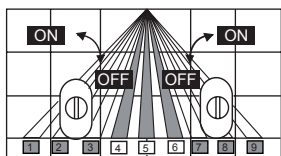

**⚠ Caution** Doors may malfunction.

- When eliminating the right/left sensing range, be sure to install the unit at place where a person approaches at the front of the door.
- In case of eliminating sensing area width: If a person approaches at the side of the door, they may not be detected and the door will not open.
- The sensing range for position of eliminating lever is as below.
- It can eliminate [1], [2], [3] by left lever and [7], [8], [9] by right lever at the once.

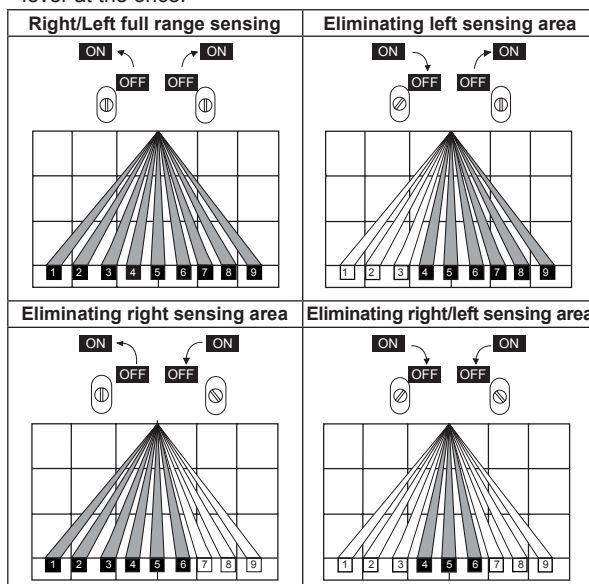

※ It is not able to eliminate individual areas like elimination of area [1] or [7].

## Adjustment

### 4. How to set the switch for interference prevention

In case of using several door sensors adjacently, please set the interference prevention switches of the sensors differently.

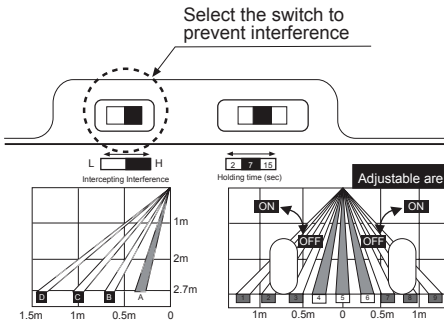

### ⚠ Caution Doors may malfunction.

When several door sensors are installed simultaneously without considering any interference prevention, it may cause malfunction by another door sensor even though there is no moving object.

#### < Interference prevention >

If sensing area of the door sensors is overlapped, set each switch in difference or install the unit on non-overlapped sensing area.

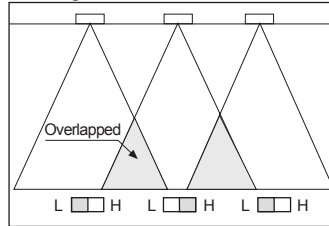

### 5. Holding time switch setting

It is able to set the holding time by the holding time switch. (selectable 2sec, 7sec, 15sec)

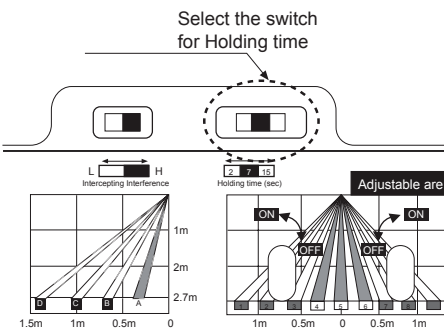

### ⚠ Caution People can be jammed in the door.

- The unit is not safety sensor. Install the fail-safe device before using the unit.
- The door will close after the time set by the holding time switch.

#### <Holding time>

When people or objects stay in sensing area after the set 7sec for holding time it will sensing the stationary people or objects for set time by the holding time switch, and then the sensor's output turns off after set time. (when people or objects stay in sensing area, output turns ON for only the set time and after the set time, output turns OFF and the door is close.)

### 6. Sensitivity Setting

- Even though people in the sensing area, if the sensor does not operate, turning the adjuster up to H. The sensitivity will be increased.



- Even though people in the sensing area, if the sensor operated, turning the adjuster up to L. The sensitivity will be decreased.

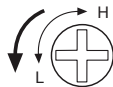

### ⚠ Caution Door can be opened and closed.

Please check the normal operation by turning the power ON/OFF after finishing the sensitivity setting. It may not operate normally after wrong sensitivity setting.

### 7. Unit cover and stripping

- Mount the cover on the unit.
- In case of using outlet to wire exposed cable, remove the cable outlet as below.

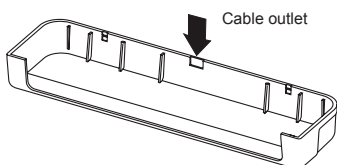

- Wrench and strip the protection cover putting a flathead screwdriver.

### ⚠ Warning It may cause electric shock.

- Use this unit with unit cover.
- Be sure that this unit does not come in direct touch with water. It may cause a damage to the equipment or cause electric shock.
- In case of without the cable outlet, the unit must be installed at inner position of door.
- Be sure that cable outlet does not come in direct touch with water. It may cause a damage to the equipment or cause electric shock.

(A) Photoelectric Sensors

(B) Fiber Optic Sensors

(C) Door/Area Sensors

(D) Proximity Sensors

(E) Pressure Sensors

(F) Rotary Encoders

(G) Connectors/ Connector Cables/ Sensor Distribution Boxes/ Sockets

(H) Temperature Controllers

(I) SSRs / Power Controllers

(J) Counters

(K) Timers

(L) Panel Meters

(M) Tacho / Speed / Pulse Meters

(N) Display Units

(O) Sensor Controllers

(P) Switching Mode Power Supplies

(Q) Stepper Motors & Drivers & Controllers

(R) Graphic/ Logic Panels

(S) Field Network Devices

(T) Software

## ■ Adjustment

<p><b>8. Sensitivity</b></p> <p>After turning on the power, please stand by in the condition without moving object in the sensing area.</p>	<ul style="list-style-type: none"> <li>• If it is not passed for 3 sec after turning the power, holding detection is impossible</li> </ul>
---	--

### 9. Check of sensing operation

Check sensing operation as the below table.

Entry activation						
Operation indicator	Orange	LED ON	LED OFF	LED OFF	LED OFF	LED OFF
	Green	LED OFF	LED ON	LED OFF	LED ON	LED ON
	Red	LED OFF	LED OFF	LED ON	LED OFF	LED OFF
Output contact					After holding time, OFF	After 0.5sec, OFF

### 10. Maintenance

- If the sensing lens is unclean, the unit may cause malfunction.
- In this case, please clean it with dry tissue and natural detergent.
- Do not use an organic materials such as benzene, etc. It may cause malfunction of sensing part.

**⚠ Warning It may cause electric shock.**

- Do not wash the unit with water.
- Do not repair or disassemble the unit.

## ■ Troubleshooting

Malfunction	Cause	Troubleshooting
It does not work.	Power voltage	Check the power cable and adjust power voltage.
	Cable cut, disconnection	Check connector and wiring.
Sometimes it does not work.	The sensing lens are unclean	Clean the lens with dry tissue and natural detergent.
The door is opened even if people do not enter in sensing area.	There are moving objects.	Check surrounding environment for installation.
	By occurring sudden change of sensing area.	Check surrounding environment for installation.
	Sensing area is overlapped.	Install the unit to avoid overlap for sensing area. Set the switch intercepting interference.
	There is the equipment such as motor, neon lamp, generator, or high voltage line causing strong electric wave, noise.	Do not install the equipment causing strong electric wave, noise near the sensor.
	A drop of water is placed at the lens.	Remove a drop of water.

## ■ Installation Environment

1. This product is not qualified for waterproof.  
Please install without being directly contacted with rain or snow, etc.  
It may cause breakdown and short circuit.

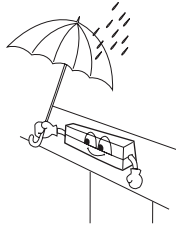

2. Do not install in the place where having reflecting light like sunshine directly reaches.  
It may does not operate normally.

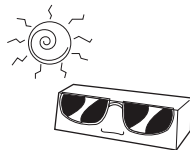

3. Do not install in the place where smoke and vapor occurs. It may do not operate normally.

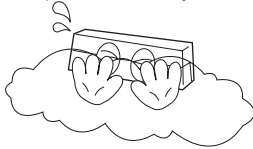

4. If you place a movable object in the sensing area, it may cause malfunction by sensing the object because of natural phenomenon like wind, etc.



5. The sensing lens must be installed face to the door's threshold. If it faces the wall or roof, it may not operate normally.

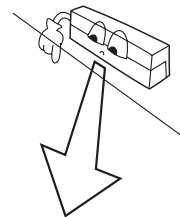

## ■ Caution For Using

### ⚠ Warning It may cause electric shock.

- Do not take off its cover when the unit is operating.  
If water is penetrated into the cable outlet, it may cause human injury or cause electric shock.
- When using this unit with cable outlet removed, this unit must be installed indoors. If installing it outdoors, it may cause electric shock or damage by direct contact with water when the water inflows through cable outlet.
- Do not wash the unit with water. Be careful not the water inflow into this unit. It may cause damage or cause electric shock.
- Do not repair or disassemble the sensor. It may cause damage or cause electric shock.

### ⚠ Caution Be careful of human injury by the door.

- Do not install this unit at place higher than 2.7m.  
It may not sense small children due to lack of sensitivity.
- Do not install this unit under 2m.  
It may not operate normally.
- The unit is not safety sensor. Install the fail-safe device before using the unit.
- Even if the unit is installed at closest side from the door, it is dangerous due to the difficulty of sensing at the closest side from the door. It is not able to detect children or the old and the infirm continuously and they can be jammed in the door.
- This unit holds the door for holding time. When the holding time passed, the door is closed. A person or an object can be jammed in the door.

### ⚠ Warning It may cause electric shock.

- When eliminating the right/left sensing area, be sure to make the object from the front of the door.  
When eliminating the right/left sensing area, it is hard to detect the enter from the width direction, it may cause human injury because the door is not opened.

### ⚠ Caution It may cause malfunction.

- When wiring the photoelectric sensor with high voltage line, power line in the same conduit, it may cause malfunction. Therefore please wire separately or use different conduit.
- Do not install this unit at place where there is dust or corrosive gas.
- The wire connection shall be used as short as possible in order to avoid malfunction by surge.
- When it is covered by dirt at lens, please clean the lens with dry cloth, but do not use any organic materials such as alkali, acid, chromic acid.

(A) Photoelectric Sensors

(B) Fiber Optic Sensors

(C) Door/Area Sensors

(D) Proximity Sensors

(E) Pressure Sensors

(F) Rotary Encoders

(G) Connectors/ Connector Cables/ Sensor Distribution Boxes/ Sockets

(H) Temperature Controllers

(I) SSRs / Power Controllers

(J) Counters

(K) Timers

(L) Panel Meters

(M) Tacho / Speed / Pulse Meters

(N) Display Units

(O) Sensor Controllers

(P) Switching Mode Power Supplies

(Q) Stepper Motors & Drivers & Controllers

(R) Graphic/ Logic Panels

(S) Field Network Devices

(T) Software