

SERIE E58 HM ANA

BLIND HOLLOW SHAFT ABSOLUTE MULTITURN ENCODER



- Analog output
- Resolution up to 16 bits
- Measuring range configurable up to 65.536 turns
- External diameter 58 mm
- Blind-Hollow shaft 6, 8, 10 or 12 mm
- Protection class IP65 according to DIN EN 60529
- Limit Switch Function
- Connection by cable (other cable length available) or industrial connector M12



BLIND HOLLOW SHAFT	Ø A
2	6
3	8
4	10
5	12

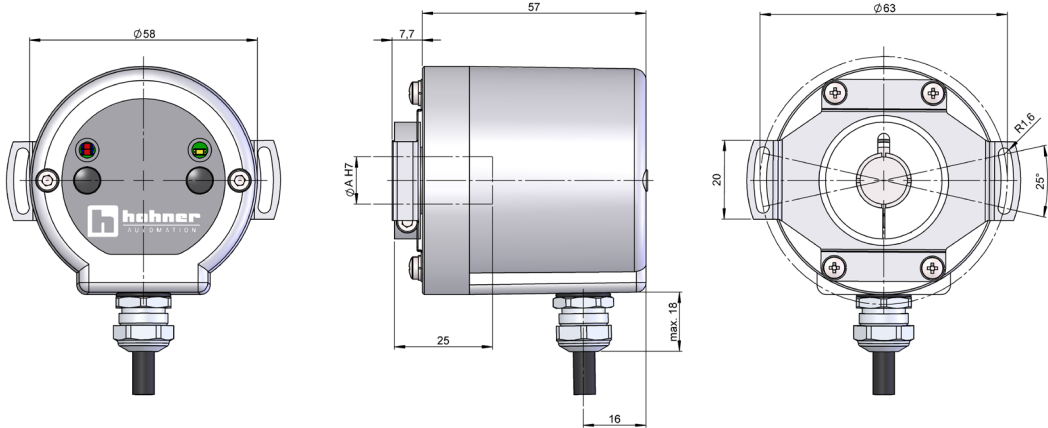

Drawing connection type 1, anti-rotation system type 3 (flexible flange 90.1027) and measuring range type CB0 or CBL

REFERENCE

Reference example: E58HM-ANA-3415-16CBL / E58HM-ANA-1227-12NC4096

Serie	Interface	Anti-rotation system	Blind-Hollow shaft	Connection	Interface / Supply Voltage	Resolution	Measuring range	Special customer
E58HM -	ANA -	<input type="checkbox"/>	<input type="checkbox"/>	<input type="checkbox"/>	<input type="checkbox"/> -	<input type="checkbox"/> <input type="checkbox"/>	<input type="checkbox"/> <input type="checkbox"/> <input type="checkbox"/>	<input type="checkbox"/> <input type="checkbox"/> <input type="checkbox"/> <input type="checkbox"/>
	ANA. Analog	1. None 2. Flexible flange (90.1018) 3. Flexible flange (90.1027) 4. Flexible flange (90.1075) (*)	2. Ø 6 mm 3. Ø 8 mm 4. Ø 10 mm 5. Ø 12 mm	1. Radial cable 2. Radial M12 5p	5. 0...20 mA, 7-30V (**) 6. 4...20 mA, 7-30V 7. 0...10V, 12-30V 8. 0...5V, 7-30V	12. 12 bits 16. 16 bits	CB0. By buttons CBL. By buttons + limit switch CC0. By cable CCL. By cable + limit switch CONFIGURABLE (1..65536)	A01Z. +105°C (****)
							NC. Not configurable (***)	

Order your reference Step file 3D

info@encoderhohner.com
service available in 24 h

(*) Anti-rotation systems type 3 and 4 supplied assembled. Anti-rotation system type 2 is supplied disassembled and includes the screws required for assembly.

(**) Only available for measuring range options CB0, CC0 and NC.

(***) Measuring range not configurable, indicate number of turns NC + 2ⁿ up to 65536 (1, 2, 4, 8, 16, 32, 64, 128, 256, 512, 1024, 2048, 4096, 8192, 16384, 32768, 65536). Preset and change of direction can be configured by cable.

(****) Only available for measuring range options CC0, CCL and NC.

Factory configuration: Measuring range: 65.536 turns - Direction: CW

SERIE E58 HM ANA

BLIND HOLLOW SHAFT ABSOLUTE MULTITURN ENCODER

MECHANICAL SPECIFICATIONS

Materials	Cover: Aluminium Housing: Aluminium Shaft: Stainless Steel
Bearings	Ballraces
Bearings lifetime	1x10 ¹⁰ rev.
Housing fixing	Flexible flange (included)
Permitted misalignment	±0.5 mm axial, ±0.3 mm radial (90.1018) ±0.5 mm axial, ±0.3 mm radial (90.1027) ±0.5 mm axial, ±0.2 mm radial (90.1075)
Shaft fixing	Clamp
Blind hollow shaft diameter	6, 8, 10 and 12 mm
Maximum number of revolutions permitted mechanically	6000 rpm
Protection against dust and splashes according to DIN EN 60529	IP65
Rotor inertia moment	60 gcm ²
Starting torque at 20°C (68°F)	≤ 0,02 Nm
Maximum load permitted on axial shaft	40 N
Maximum load permitted on radial shaft	80 N
Weight aprox.	0,5 Kg
Operating temperature range	-40°C to +85°C - Standard -40°C to +105°C - Special Customer A01Z
Vibration according to DIN EN 60068-2-6	100 m/s ² (10Hz...2000Hz)
Shock according to DIN EN 60068-2-27	1000 m/s ² (6ms)
Radial connection	2 meters cable or industrial connector M12 (other cable lengths available on order) Female connector not included

ELECTRICAL SPECIFICATIONS

Interface	Analog
Electronic output	0..20mA , 4..20mA, 0..5V, 0..10V
Power supply (VCC)	7-30V, 12-30V
Consumption	≤ 100 mA
Resolution	12 or 16 bits
Range	up to 65.536 turns
Configurable parameters	Range, Direction and Preset
Rollover mode	Yes
Frequency	100 kHz
Short circuit protection	Yes
Protection polarity inversion	Yes

CONNECTION



	Cable 5x0,14 95.0008051	Connector M12 5p CCW
GND	Yellow	1
VCC	White	2
SET1 / DIR	Brown	3
SET2 / PRESET	Green	4
I _{out} / V _{out}	Grey	5

SERIE E58 HM ANA

BLIND HOLLOW SHAFT ABSOLUTE MULTITURN ENCODER

MEASURING RANGE CONFIGURATION

CONFIGURABLE BY BUTTONS (OPTIONS CBO AND CBL)

1. Press PB1 and PB2 together for 15 sec. to enter programming mode.
2. Turn the shaft to the start measuring position.
3. Press PB1 or PB2 for 2 seconds, then the green led lights solidly.
4. Turn the shaft to the end measuring position.
5. Press the other PB not configured for 2 seconds, then the green led lights solidly.

CONFIGURABLE BY CABLE (OPTIONS CCO AND CCL)

1. Turn the shaft to the start measuring position.
2. Connect SET1 or SET2 with +V for at least one second.
3. Turn the shaft to the end measuring position.
4. Connect the other SET not configured with +V for at least one second.

If the process is not set up correctly, the encoder gives an electronic output of 12 mA in Interface / Supply Voltage options 5 (0..20 mA, 7-30V) and 6 (4..20 mA, 7-30V), or half of maximum voltage in options 7 (0..10 V, 12-30V) and 8 (0..5 V, 7-30V).

NOT CONFIGURABLE (OPTION NC)

Direction

1. Set direction before Zero Setting the encoder.
2. If DIR pin is connected to GND or not connected, the encoder has an increasing output signal when the shaft is turned CW.
3. If DIR pin is connected to $\geq 5V$ up to max supply voltage, the encoder has an increasing output signal when the shaft is turned CCW. DIR pin needs to be always connected to $\geq 5V$.

Preset

1. Turn the shaft to the position you want to set to zero.
2. Connect PRESET pin to $\geq 5V$ up to max supply voltage for at least $T=100$ ms.
3. Disconnect the PRESET pin, now the encoder is set to zero at the actual shaft position.
4. Make sure that the shaft is not move during the set to zero procedure.

OUTPUT SIGNALS

Configurable version mA without Limit Switch function

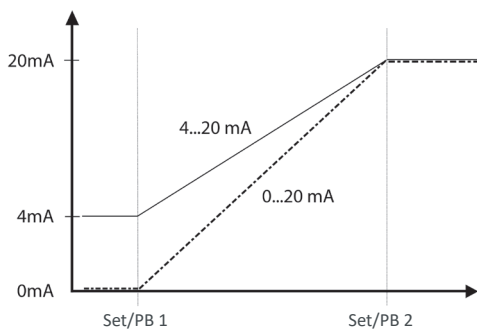

Configurable version mA with Limit Switch function

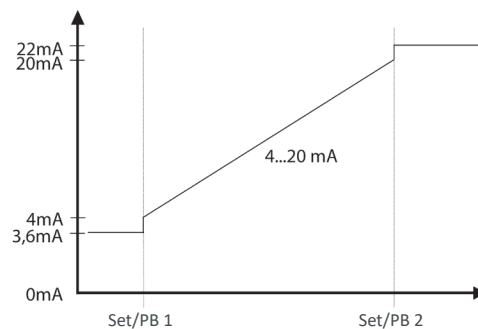

Interface	4...20mA
Low	3.6mA
High	22mA

SERIE E58 HM ANA

BLIND HOLLOW SHAFT ABSOLUTE MULTITURN ENCODER

Configurable version V without Limit Switch function

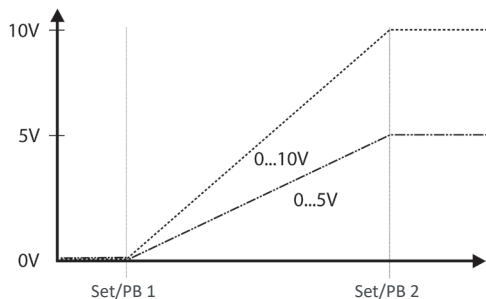

Configurable version V with Limit Switch function

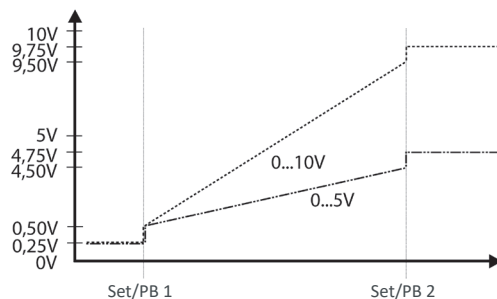

Interface	0...5V	0...10V
Low	0.25V	0.25V
High	4.75V	9.75V

Not configurable version V (Voltage)

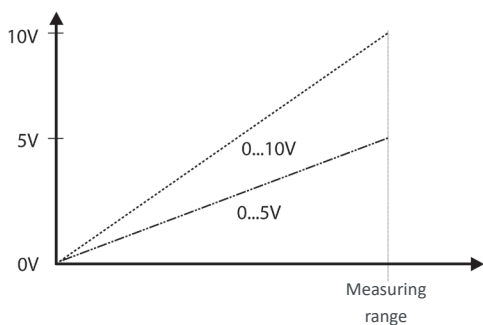

Not configurable version mA (Current)

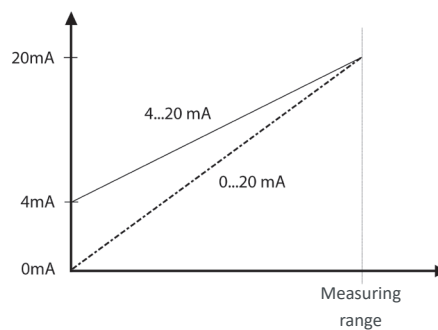

CONNECTION DIMENSIONS

Female connector not included

Connection 2

Radial
M12 5p
male panel
counter clockwise

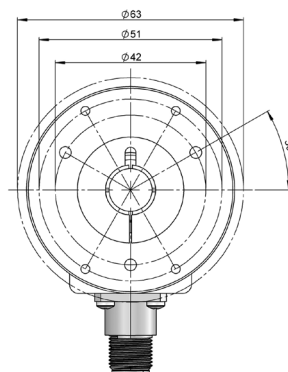
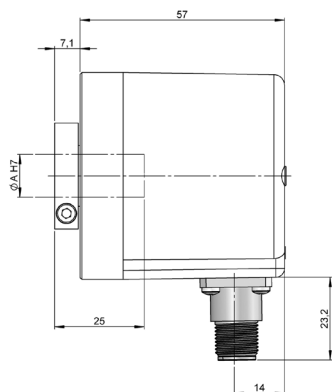

Female connector
95.0007265

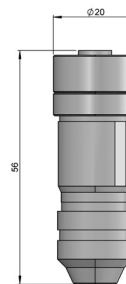

SERIE E58 HM ANA

BLIND HOLLOW SHAFT ABSOLUTE MULTITURN ENCODER

ANTI-ROTATION SYSTEMS DIMENSIONS

Anti-rotation system 2

Flexible flange
90.1018

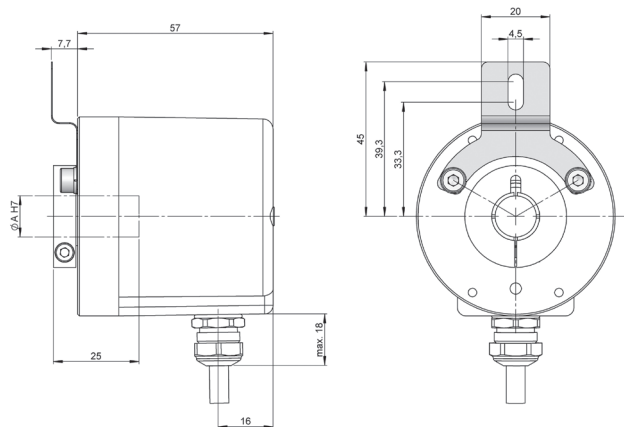

90.1018



Anti-rotation system 4

Flexible flange
90.1075

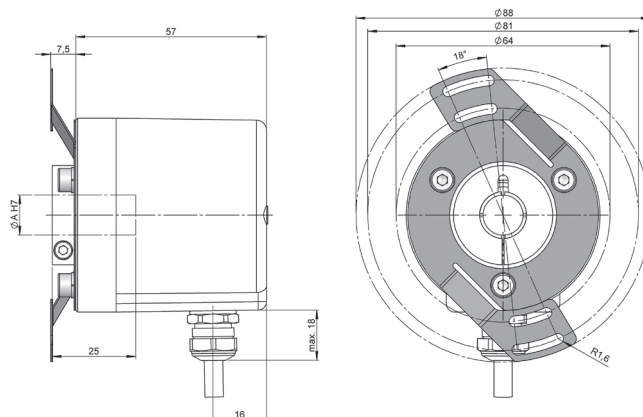

90.1075

