

## FIELDLED EVO 702\_150 Aufbau, 702 mm, 24V DC

**Artikel-Nr.:** 153510-01  
**EAN:** 4260556625591

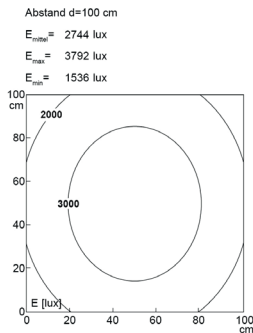

<b>Bestell-Nr.:</b>	153510-01
<b>Modell:</b>	FIELDLED EVO 96 Aufbau
<b>Bauform:</b>	LED Aufbauleuchte für Maschinen
<b>Leuchtmittel:</b>	SMD LED
<b>Lampenleistung:</b>	~86 W
<b>Lampenlichtstrom:</b>	13400 lm
<b>Lampenlichtausbeute:</b>	155 lm/W
<b>Lichtverteilung:</b>	direkt
<b>Lichtfarbe:</b>	Tageslichtweiß (5200 - 5700K)
<b>Anschlusswert Leuchte:</b>	24V DC ± 10%
<b>Anschluss Leuchte:</b>	M12 Sensorstecker A-kodiert, stirnseitig
<b>Schutzart:</b>	IP67/IP69K
<b>Schutzklasse:</b>	III
<b>Entblendung:</b>	Mikroprismen
<b>Abstrahlwinkel:</b>	100°
<b>Betriebstemperatur:</b>	-30... +60 °C
<b>Farbwiedergabe (Ra):</b>	> 85
<b>Lampenlebensdauer:</b>	> 60.000 h
<b>Material Gehäuse:</b>	Aluminium
<b>Material Abdeckung:</b>	ESG (Sicherheitsglas), splitterfrei
<b>Höhe [B] x Breite [C]:</b>	30 x 150 mm
<b>Länge [A]:</b>	702 mm
<b>Gewicht:</b>	~3200 g
<b>Bruttogewicht:</b>	~4000 g
<b>Risikogruppe (DIN EN 62471):</b>	freie Gruppe
<b>Befestigungszubehör:</b>	optional; 2 Schraubkanäle für M5 rückseitig
<b>Dimmbar:</b>	optional über Zubehör
<b>Kennzeichnung:</b>	CE, UKCA, ETL Listed (5003526)
<b>Gefertigt in:</b>	Deutschland



Abstand [m]	Kegeldurchmesser [m]	Beleuchtungsstärke [lx]
0.5	1.06	E(0°) 16294
	0.93	E(C90) 46.8° 2616
		E(CD) 42.9° 3327
1.0	2.13	E(0°) 4066
	1.86	E(C90) 46.8° 654
		E(CD) 42.9° 802
1.5	3.19	E(0°) 1807
	2.79	E(C90) 46.8° 291
		E(CD) 42.9° 356
2.0	4.26	E(0°) 1016
	3.72	E(C90) 46.8° 168
		E(CD) 42.9° 200
2.5	5.32	E(0°) 651
	4.65	E(C90) 46.8° 105
		E(CD) 42.9° 138
3.0	6.39	E(0°) 452
	5.58	E(C90) 46.8° 73
		E(CD) 42.9° 89

Abstand [m]      Kegeldurchmesser [m]      Beleuchtungsstärke [lx]

— C0 - C180 (Halbstrahlwinkel: 85.8°)  
 — C90 - C270 (Halbstrahlwinkel: 93.4°)

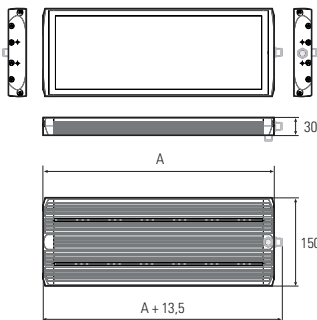

Lampenlebensdauer in Betriebstunden (L80/B10)



## FIELDLED EVO 702\_150 Aufbau, 702 mm, 24V DC

**Item number:** 153510-01  
**EAN:** 4260556625591



<b>Order number:</b>	153510-01
<b>Model:</b>	FIELDLED EVO 96 Aufbau
<b>Type:</b>	LED surface-mounted luminaire for machines
<b>Illuminant:</b>	SMD LED
<b>Power consumption:</b>	~86 W
<b>Lamp luminous flux:</b>	13400 lm
<b>Lamp luminous efficiency:</b>	155 lm/W
<b>Light distribution:</b>	direct
<b>Light colour:</b>	daylight white (5200 - 5700K)
<b>Connected load:</b>	24V DC $\pm$ 10%
<b>Connection:</b>	M12 sensor connector, A-type encoded, front-end
<b>Degree of protection:</b>	IP67/IP69K
<b>Class of protection:</b>	III
<b>Glare-free</b>	microprism
<b>Beam angle (optics):</b>	100°
<b>Operating temperature:</b>	-30... +60 °C
<b>Colour rendering (Ra):</b>	> 85
<b>Lamps lifetime:</b>	> 60,000 h
<b>Housing material:</b>	aluminium
<b>Cover material:</b>	ESG (toughened safety glass), shatterproof
<b>Height [B] x Width [C]:</b>	30 x 150 mm
<b>Length [A]:</b>	702 mm
<b>Weight (net):</b>	~3200 g
<b>Gross weight:</b>	~4000 g
<b>Risk group (DIN EN 62471):</b>	free group
<b>Mounting accessories:</b>	optional; two continuous screw channels for metric screws with thread M5 on the reverse
<b>Dimmable:</b>	via optional accessory
<b>Marking:</b>	CE, UKCA, ETL Listed (5003526)
<b>Made in:</b>	Germany

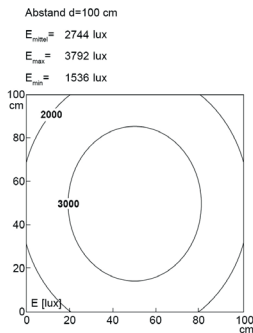

Abstand [m]	Kegeldurchmesser [m]	Beleuchtungsstärke [lx]
0.5	1.06	E(0°) 16294
	0.93	E(C90) 2616
1.0	2.13	E(0°) 4066
	1.86	E(C90) 654
1.5	3.19	E(0°) 1807
	2.79	E(C90) 291
2.0	4.26	E(0°) 1016
	3.72	E(C90) 168
2.5	5.32	E(0°) 651
	4.65	E(C90) 105
3.0	6.39	E(0°) 452
	5.58	E(C90) 73

— C0 - C180 (Halbstrahlwinkel: 85.8°)  
— C90 - C270 (Halbstrahlwinkel: 93.4°)

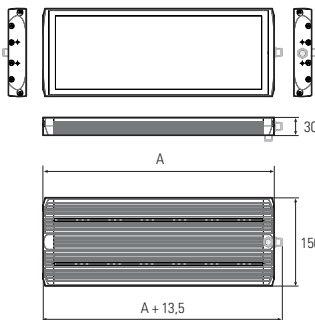

Lamps lifetime in operation hours (L80/B10)