

LED Zubehör
 LED accessories

**FIELDLED EVO Leuchtenhalter, schwenkbar 150°,
 1 Paar**

Artikel-Nr.:	210200-21
EAN:	4260556625676

Bestell-Nr.:	210200-21
Bauform:	Winkel
Anzahl:	1 Paar
Geeignet für:	FIELDLED EVO Aufbau
Lieferumfang:	Leuchtenhalter, 2 Stück
Material:	Edelstahl V2A
Abmessungen (mm):	94 x 25 x 74 (Raummaß)
Befestigung an Leuchte:	Haltewinkel zur Montage an Stirnseite der Leuchte
Gewicht:	150 g
Bruttogewicht:	200 g

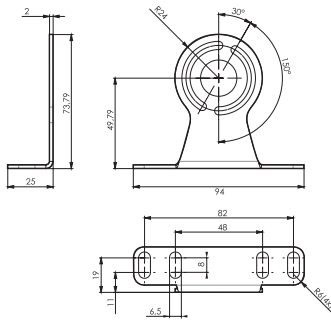
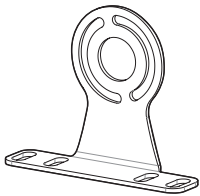



FIELDLED EVO luminaire holder, pivotable 150°, 1 pair

Item number: 210200-21
EAN: 4260556625676

Order number: 210200-21
Model: mounting bracket
Quantity: 1 pair
Suitable for: FIELDLED EVO Aufbau
Scope of delivery: luminaire holders, 2 pieces
Material: stainless steel V2A
Dimensions (mm): 94 x 25 x 74 (cubic measure)
Assembling: holders for assembling at the end caps of the luminaire
Weight (net): 150 g
Gross weight: 200 g

